

Installation Manual and Operating Guidelines for Fiberglass Underground Storage Tanks



2. 4. 1. 1. 3

Installation Manual and Operating Guidelines for Fiberglass Underground Storage Tanks

READ BEFORE INSTALLING TANK

Read all instructions, supplemental materials and operating guidelines before installation.

Compliance with the installation instructions and operating guidelines contained in this Installation Manual and Operating Guidelines (subsequently referred to as the Installation Manual) are necessary for the proper installation, maintenance and use of our tanks and accessories. For proper installation of some tanks and accessories, it may also be necessary to consult select supplemental materials referenced in the **Introduction**.

Failure to comply will void our obligations under the applicable limited warranty for the tank(s) and could result in death, serious injury, property damage or tank failure.

To Installer

Before installation, read and understand the Installation Manual and any applicable supplemental materials. After tank installation, deliver the Installation Manual with the completed Tank Installation Checklist (**Appendix E**) to the tank owner.

To Owner

After installation, retain the limited warranty, the Installation Manual and checklist for future reference and follow all operating guidelines in the Installation Manual.

TABLE OF CONTENTS

Glossary	02
Introduction	03-04
• Use of Tank Data Charts	03
• Supplemental Materials	04
• Limited Warranties	04
I: Planning for Installation	04-14
• General	04
• Backfill Material and Geotextile	04-05
• Excavation Requirements	05-14
2: Handling and Storing Tanks	14-15
• General	14
• Unloading, Hoisting and Guiding Tanks	14-15
• Storing Tanks	15
3: Preinstallation Inspection and Testing	15-16
• General	15
• Inspecting the Tank	16
4: Testing During Installation	16-20
• Tanks Types	16
• Pressure-Test Pretesting Procedures	16

• Preparing the Tank for Pressure Testing	16-17
• Pressurizing the Primary Tank	17
• Pressurizing the Interstitial Space in a Dry Tank	17
• Soaping the Tank	17-18
• Performing Visual Checks on a Tank with Wet Interstitial Space	18
• Releasing Pressure From the Tank	18
• Testing for Specific Types of Pressure-Testable Tanks	18-20
• Pressure-Testing Sidebar	19
5: Installing Tanks	20-23
• General	20
• Dry Hole Installation	20-21
• Wet Hole Installation	22
• Bottom Sumps and Fittings	22
• Ballasting Tanks (Adding Liquid)	22-23
6: Postinstallation Testing	23
• Pressure Testing Tanks	23
• Optional Hydrostatic Testing	23
7: Piping, Venting and Containment Sumps ...	23-25
• Internal Piping	23
• External Piping	23
• Venting Tanks	23
• Piping Sidebar	24
• Venting Interstitial Spaces	25
• Installing Containment Sumps	25
8: Completing Installation	26-27
• Taking Diameter Measure #4	26
• Monitoring Tanks	26
• Monitoring Single-Wall Tanks	26
• Monitoring Double-Wall Tanks	26
• Monitoring Double-Wall Tank With a Dry Interstitial Space	26
• Monitoring Double-Wall Tank With a Wet Interstitial Space	26
• Setting the Level of the Monitoring Fluid	26-27
9: Operating Guidelines	27-28
• General	27
• Temperature Limits for Stored Products and Materials	27
• Entering Tanks	27
• Filling Tanks (In General)	28
• Filling UL-Labeled/ULC-Labeled Tanks	28
10: Document Review	28
• Installation Manual	28
• Appendices	28
Appendices AI-A4	29-35
Appendices BI-B4	36-42
Appendix C	43
Appendix D	44
Appendix E	45-47

GLOSSARY

Access opening

On a water or wastewater tank, an access opening is a non-flanged, non-bolted opening designed to provide personnel access to the interior of the tank.

Baffle

On a water or wastewater tank, a baffle is a partition wall that may extend the full tank height.

Base Tank

On a multicompartment fuel tank, a base tank is the compartment with two convex domed endcaps that serve as bulkheads to another compartment.

Containment sumps

A containment sump is a single-wall or double-wall enclosure to be installed above underground storage tanks. It is used as a termination point for piping and tank access openings.

Double-wall (DW) tank

A double-wall tank is a tank with a primary (inner) wall surrounded by a secondary (outer) wall, with a monitorable space between the primary wall and the secondary wall.

Dry monitor fitting

On a dry-monitored double-wall tank, a dry monitor fitting is the accessory that provides access to the interstitial space.

End compartment

On a multicompartment fuel tank, an end compartment is the compartment with one convex and one concave domed endcap.

Flat

Flat is a common term used to describe the area between the ribs on the outside of the tank.

Green Tank

A green tank is a tank manufactured in Canada.

Interstitial space

Also referred to as "interstice" or "annular space," an interstitial space is the region between any two walls of a tank or tank accessory.

Manway

A manway is the flanged fiberglass opening (typically 22-inch, 30-inch or 36-inch in diameter) that provides access to the primary tank and/or is used for multiple service fittings that are welded to a bolt-on steel manway cover.

Monitor fitting

On a double-wall tank, a monitor fitting is the accessory that provides access to the interstitial space.

Monitoring fluid

Also referred to as "brine," on a hydrostatically monitored double-wall tank, monitoring fluid is the fluid that is added to interstitial space. The monitoring fluid that we commonly use is an approximately 30% calcium chloride solution that is dyed blue to help differentiate it from other fluids.

Pressure relief valve

A pressure relief valve is the valve that automatically opens at a set pressure to relieve pressure if it rises above the set point.

Pressure testing

Pressure testing is the use of air or inert gas pressure and soapy water solution to create soap bubbles as an indication of a problem with the tank.

Primary backfill

Primary backfill is rounded or crushed stone conforming to the requirements listed in **Appendix C**.

Primary tank

A primary tank is the inner tank (product storage tank) of a multiple-wall tank.

Red Tank

A red tank is a tank manufactured in the United States.

Reservoir

On a hydrostatically monitored double-wall tank, a reservoir is the small expansion chamber at the top of the tank used for monitoring the fluid level in the interstitial space.

Rib

A rib is the fiberglass reinforcement integrally manufactured around the circumference of the tank and evenly spaced along the length of the tank.

Secondary backfill

Secondary backfill is the granular material conforming to the requirements listed in **section 1** that may be used as an alternative to primary backfill above the tank in some conditions.

Secondary tank

A secondary tank is the second wall of a multiple-wall tank. For a double-wall tank, this wall of the tank is visible from the exterior.

Single-wall (SW) tank

A single-wall tank is a tank having only one wall separating its contents from the external environment.

Test manifold

A test manifold is an assembly of components including pipe fittings, nipples, valves, hose, pressure gauges and a pressure relief valve, used for controlling and monitoring pressure during a pressure test.

TRUCHEK®

TRUCHEK® is our patented hydrostatic, tank-monitoring system for double-wall tanks. It is an easy, reliable method for true continuous leak detection and tank-tightness testing.

Torque rating

Torque rating is the maximum allowable rotational load that can be applied to tighten threads. The bolt torque rating of flanged fiberglass fittings and manways on our tanks is 25 foot-pounds.

Unattached riser

An unattached riser is a chamber with an open bottom above the tank, with no attachment to the tank.

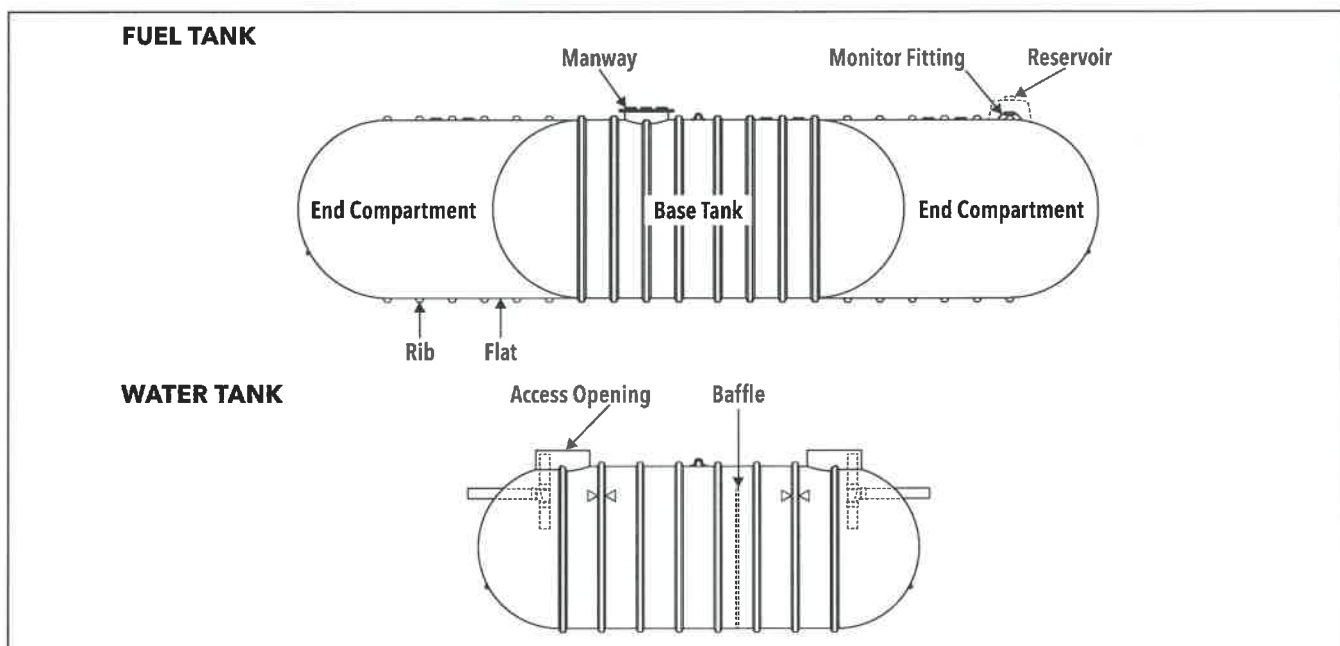

INTRODUCTION

- 1.** Before beginning the tank installation, read through the entire Installation Manual and Operating Guidelines (subsequently referred to as the Installation Manual) and any applicable supplemental materials. It is the responsibility of the owner, installer and operator to understand and follow all requirements contained in the Installation Manual.
- 2.** Work must be performed according to standard industry practices applicable to tank installations and operations.
- 3.** Work must comply with all codes, regulations and standards of appropriate governmental agencies, such as:
 - construction, health, safety and environmental codes
 - relevant US fire codes (for example, National Fire Protection Association standards 30, 30A and 31)
 - relevant Canadian fire codes (for example, National Fire Code of Canada and provincial fire codes)
 - industry standard practices (for example, PEI RP100, API RP1615)
- 4.** For additional information, contact appropriate governmental agency storage-tank authorities, include fire or building departments, and environmental agencies.
- 5.** The following safety designations will apply when reading the Installation Manual:
 - ⚠ WARNING** Indicates a potentially hazardous situation, which, if not avoided, could result in death or serious injury.
 - ⚠ CAUTION** Indicates a potentially hazardous situation, which, if not avoided, could result in minor or moderate injury.
 - NOTICE** Indicates information considered important but not hazard related. Failure to heed this notice could result in property damage.
- 6.** Keep the Installation Manual available at the installation site to refer to safety procedures as needed.
 - ⚠ WARNING**
Follow OSHA regulations and/or consult your local Canadian regulations concerning tank excavations, whichever are relevant. Collapse of excavation walls could result in death or serious injury.
- 7.** Working in and around excavations is dangerous. Prior to beginning work at the site, the installer must follow any governmental or other codes and/or regulations applicable to excavations.
- 8.** Careless activity or reckless operation of equipment can cause death, serious injury or property damage.
- 9.** Governmental agency codes, regulations and standards always take precedence over our requirements.
- 10.** No instructions or procedures presented in the Installation Manual should be interpreted so as to put at risk any person's health or safety, or to harm any property or the environment.
- 11.** It is important to follow the procedures and instructions in the

Installation Manual in order to safely and properly install our underground storage tank and accessories.

- Failure to follow these instructions will void our obligations under the limited warranty, could result in death, serious personal injury, property damage and/or tank failure.
 - The presence of our representative does not relieve the installer of having sole responsibility for proper tank installation.
- 12.** Our limited warranty applies only to a tank installed according to these instructions. Since we do not control the parameters of any installation, our sole responsibility in any installation is that presented in the limited warranty.
 - 13.** It is the responsibility of the owner and operator to always follow the operating guidelines set forth in our applicable limited warranty.
 - 14.** It is the responsibility of the owner and operator to always follow the operating guidelines set forth in **section 9** of the Installation Manual.
 - 15.** It is the responsibility of the owner to retain the limited warranty and the Installation Manual provided with the tank for future reference. Go to zcl.com for a copy of the current limited warranty.
 - 16.** Use the Tank Installation Checklist (**Appendix E**) for all underground storage tanks throughout the installation process.
 - 17.** Record the relevant information for each tank installed on the Tank Installation Checklist. Additional copies are available at zcl.com.
 - 18.** Tank installer must retain a copy of the completed Tank Installation Checklist and provide tank owner with a copy in order to facilitate any warranty claim.
 - 19.** Any variation to, or deviation from, the instructions in the Installation Manual must be approved in writing from us prior to the tank installation.
 - All correspondence regarding any variances must be retained in the event of a future warranty claim.
 - 20.** For any questions regarding the interpretation of these instructions or for any other technical inquiries, contact technical support (eng.support@zcl.com).
 - 21.** All contact information applicable to installation is found on the back cover of the Installation Manual.

USE OF TANK DATA CHARTS (APPENDICES A & B)

- 22.** Tank data charts—**Appendices A1, A2, A3 and A4** (Actual Capacities and Dimensions of Single-wall and Double-Wall Tanks) and **Appendices B1, B2, B3 and B4** (Weights of Single-Wall, Double-Wall and Multicompartments Tanks)—address the most frequently sold tanks. For information on additional tank sizes, contact technical support (eng.support@zcl.com).
 - **Appendices A1 and B1** apply to tanks manufactured and installed in the United States (red tanks).
 - **Appendices A2 and B2** apply to tanks manufactured in Canada and installed in the United States (green tanks).
 - **Appendices A3 and B3** apply to tanks manufactured and installed in Canada (green tanks).
 - **Appendices A4 and B4** apply to tanks manufactured in the United States and installed in Canada (red tanks).
- 23.** **Appendices A** charts are intended for use with individual single-wall and double-wall, one-compartment tanks.

24. Actual capacities shown will be reduced if an overflow-protection device is installed in the tank.

25. Actual tank height may be greater than that shown with actual tank diameter when certain accessories are installed on a tank.

26. Load height during shipping may vary due to tank placement on the shipping trailer.

27. When using **Appendices B1, B2, B3** and **B4** for determining the weight of a multicompartment tank, you must select the tank size in the chart given the total nominal capacity of all compartments. Note the following:

- Single-wall (SW) tanks with flat baffle(s) installed are not considered multicompartment tanks. Refer to one-compartment tank data for these tanks.
- For double-wall (DW) tanks with a dry interstice, use the DW Dry Weight column.
- For double-wall (DW) tanks with a factory-installed TRUCHEK® wet monitoring interstice, use the DW Wet Weight column.

SUPPLEMENTAL MATERIALS

28. Go to zcl.com to view tank installation training videos.

29. Supplemental materials, which may apply to specific installations and/or conditions, are available upon request from technical support (eng.support@zcl.com). Most supplemental materials are also available at zcl.com.

30. Among those materials available from technical support (eng.support@zcl.com) and at zcl.com are the following:

- Diesel Exhaust Fluid (DEF) Tank Installation Instructions
- Double-Wall Containment Sump Installation Instructions
- Dry Interstitial Space Test
- Field Fiberglass Lay-Up Instructions for Containment Sumps
- Flexible Dipstick Monitoring Instructions (Canada only)
- Hook/Hook Anchor Straps Instructions (Canada only)
- Large Bottom Sump Installation Instructions
- Oil/Water Separator Operating and Maintenance Manual
- Preinstallation Testing Instructions for Water/Wastewater Tanks Factory-Equipped for Pressure Testing
- TRUCHEK® Data Log and Testing Procedure
- Single-Wall Containment Sump Installation Instructions for Flat-Sided Containment Sumps
- Single-Wall Containment Sump Installation Instructions for Round Containment Sumps
- Triple-Wall Tank Preinstallation Testing Instructions (US only)
- Watertight Cover Gasket Replacement Instructions (US only)

LIMITED WARRANTIES

31. Our applicable limited warranty contains operating guidelines and limitations that should be reviewed as applicable. Copies of our current limited warranties are found at zcl.com.

I: PLANNING FOR INSTALLATION

I.1. GENERAL

I.1.1. This section of the Installation Manual contains information that you need to consider before a tank is delivered so that you are prepared to proceed with installation. This includes, but is not limited to, equipment needed for installation, backfill material selection, excavation requirements, tank anchoring options, taking diameter measurements, and onsite testing requirements.

I.1.2. The following list is to be used as a guide for equipment recommended for tank installation:

- excavation equipment capable of producing a level-bottom hole and placing backfill material at any point in the excavation
- suitable lifting equipment capable of lifting and placing the tanks and associated tank anchors
- spirit level
- transit or grade level
- 50-foot [15-meter] tape measure
- tamping rod(s)
- pipe wrenches and appropriate pipe joint compound
- a test manifold for each pressure-testable tank or compartment (reference **Figure 4-1**)
- source of pressurized air capable of 6 psig [40 kPa] or inert gas
- soap and water solution (during freezing conditions, a suitable solution such as windshield wiper fluid may be added to the soap and water mixture)
- soft cloth, brush or hand-held pneumatic sprayer
- hand shovel
- lifting sling(s)
- soil compacting equipment (if necessary)

I.2. BACKFILL MATERIAL AND GEOTEXTILE

I.2.1. GENERAL

I.2.1.1. Tanks shall be installed using select rounded stones or crushed stones as primary backfill material. See **section 1.2.2** for specifications of primary backfill material and **Appendix C**.

I.2.1.2. Alternatively, tanks shall be installed using primary backfill vertically up to at least 75 percent of the tank diameter and secondary backfill above the primary backfill. See **section 1.2.3** for specifications of secondary backfill and Split Backfill Instructions (**Appendix D**) for more information regarding this alternative.

I.2.1.3. Using backfill material other than that specified here without prior written authorization from us will void our obligations under the applicable limited warranty.

NOTICE

Using other than specified backfill material could cause tank failure, or could result in damage to the tank and/or surrounding property.

I.2.2. PRIMARY BACKFILL

I.2.2.1. Primary backfill material must meet the following specifications:

- Material is to be clean, free-flowing, and free of dirt, sand, large rocks, roots, organic materials, debris, ice and snow.
- Backfill material shall not be frozen or contain lumps of frozen material at any time during placement and compaction.

- An important characteristic of good backfill material is hardness or stability when exposed to water or loads. Most materials have no problem meeting the hardness requirement.
- Materials like soft limestone, sandstone, sea shells or shale should not be used as backfill because they may break down over time.
- When using select rounded stones, they must conform to the specifications of ASTM C 33, size numbers 6, 67 or 7. See Primary Backfill Requirements (**Appendix C**) for additional information on backfill material specifications.
- When using select crushed stones, they must conform to the specifications of ASTM C 33, size numbers 7 or 8. See Primary Backfill Requirements (**Appendix C**) for additional information on backfill material specifications.

I.2.2.2. We recommend that the supplier of backfill material provide the tank installer and tank owner with written certification that the material conforms to ASTM C 33, ASTM D 448, AASHTO M 43, and any other applicable specifications.

I.2.2.3. If primary backfill material which meets these specifications is not available, contact technical support (eng.support@zcl.com) for information on alternate materials, installation instructions for alternate materials and the process for approval.

I.2.3. SECONDARY BACKFILL

I.2.3.1. When used (see **Appendix D**), secondary backfill material must meet the following specifications:

- Material is to be clean, free-flowing, and free of large rocks, roots, organic materials, debris, ice and snow.
- Backfill material shall not be frozen or contain lumps of frozen material at any time during placement and compaction.
- Material must be compacted to achieve a minimum of 85 percent standard proctor density.
- 100% of all backfill material must pass through a 1-inch [25-mm] sieve.

I.2.3.2. Material must be installed in 12-inch to 24-inch [30-cm to 61-cm] lifts compatible with the compaction equipment used.

I.2.3.3. In some conditions, frost heave may be encountered when using secondary backfill. Therefore, consider any frost-related problems that may occur.

I.2.3.4. Specifications for secondary backfill material and compaction above the filter-fabric layer may be determined by the requirements of the piping, surface slab or roadway.

I.2.3.5. Refer to applicable codes or standards for base course and sub-base course material and compaction requirements.

I.2.3.6. The following are examples of acceptable secondary backfill material:

- clean native backfill
- coarse sand
- gravel

I.2.4. GEOTEXTILE

I.2.4.1. Using geotextile fabric is considered good installation practice and using it in any installation is recommended, especially when the tank is installed in the following conditions:

- areas with frequently changing groundwater conditions or areas subject to tidal fluctuations
- unstable soils such as those cited in **section 1.3.5.3**
- water conditions with silty in-situ soil

I.2.4.2. Geotextile helps preserve the integrity of the select backfill envelope that surrounds and supports the tank.

- Geotextile fabric allows the passage of water in and out of the excavation but prevents the migration and mixing of in-situ soil and the select backfill material.
- Polyethylene film is not considered an effective geotextile material because it may tear or degrade while in service.
- If geotextile is used, install geotextile before placing bedding material.
- The tank owner or the owner's technical representative is responsible for determining whether a geotextile or an alternate filtering technique is appropriate for a specific installation.

I.2.4.3. Where both primary and secondary backfill are used, a layer of geotextile filter fabric must be installed over the entire surface of primary backfill material before secondary backfill is placed. Note the following instructions:

- All joints in the filter fabric must be overlapped a minimum of 12 inches [30 cm].
- Geotextile fabric must overlap onto the tank and excavation surface a minimum of 12 inches [30 ml].
- See Split Backfill Instructions (**Appendix D**) for more information regarding this installation situation.

I.3. EXCAVATION REQUIREMENTS

▲ WARNING

Consult OSHA's regulations, and/or applicable Canadian federal, provincial and municipal safety codes and operational regulations, whichever are relevant. Collapse of excavation walls could result in death or serious injury.

I.3.1. GENERAL

I.3.1.1. The installing contractor must take all necessary precautions in or near a tank excavation. These precautions should include but are not limited to the following:

- Locate and protect any utility installations near the excavation before opening the excavation.
- Secure the walls of the excavation.
- Take appropriate precautions to protect against exposure to hazardous vapors from the excavation.
- Avoid hazards associated with water accumulation in the excavation.
- Erect barricades, etc., to prevent unauthorized vehicle or pedestrian traffic.
- Inspect, a minimum of once a day, the excavation and surrounding area during the entire installation process.

I.3.1.2. For additional information on excavation, trenching and shoring safety practices, consult OSHA's regulations, and/or applicable Canadian federal, provincial and municipal safety codes and operational regulations, whichever are relevant.

▲ WARNING

Follow OSHA regulations or consult your local Canadian regulations concerning tank excavations, whichever are relevant. Collapse of excavation walls could result in death or serious injury.

I.3.1.3. The minimum clearance dimensions given in this section are important to the successful installation of a tank.

I.3.1.4. Additional clearances may be necessary due to regulations, safety requirements or operational requirements of governmental agencies. Follow all applicable regulations and safety practices.

1.3.1.5. For additional requirements and specifications, consult all codes and regulations of governmental agencies. See the **Introduction** for additional information.

1.3.2. EXCAVATION AND TANK LOCATION

1.3.2.1. We recommend that the tank owner seek the advice of a local foundation professional engineer to determine the proper placement of a tank excavation near any existing structure(s).

NOTICE

Improper placement of the excavation could result in damage to the tank and/or property damage.

1.3.2.2. The tank owner and/or the owner's technical representative is responsible for determining the proper placement of a tank excavation.

1.3.2.3. In general terms, the size of the excavation is determined by:

- the number of tanks to be installed
- the size of the tanks to be installed

1.3.2.4. The location of a tank can be affected by the location of nearby structures. When selecting a tank site, care must be taken to avoid undermining the foundations of existing structures or new buildings to be constructed. See **Figure 1-1**.

- Ensure that downward forces from loads carried by the foundations and supports of nearby structures (constructed before or after tank installation) are not transmitted to the tanks.

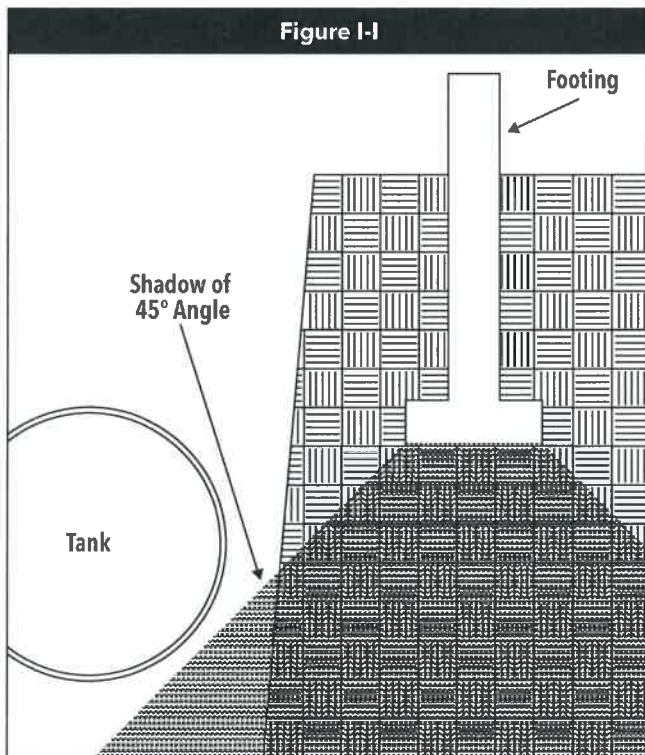

1.3.2.5. Typically, the way to check the placement of the tank in relationship to a nearby structure is to do the following:

- determine the depth of burial needed for the tank
- locate the footing of the structure to be considered
- determine the line that would fall into the ground from a 45-degree angle drawn downward from the corner(s) of the footing of the foundation that is closest to the tank

1.3.2.6. The tank must not fall within the "shadow" of the 45-degree angle line drawn from the foundation's footing. See **Figure 1-1**. If the tank would fall within this "shadow," do one of the following to ensure that the tank does not fall within the "shadow":

- move the tank away from the existing building
- move the foundation of the building to be constructed away from the tank
- deepen the footing of the planned building's foundation

1.3.3. DEPTH OF EXCAVATION

1.3.3.1. Typically, the depth of the excavation is determined by:

- groundwater conditions
- traffic at the site
- soft or uneven excavation base
- pipeline grade requirements and/or invert elevations
- codes and regulations

1.3.3.2. Groundwater must be considered if the level of water in the ground may rise above the bottom of the tank at any time during the life of the tank.

1.3.3.3. Traffic loads are considered to be loadings for highway vehicles up to H-20 or HS-20 as defined in the AASHTO Standard Specifications for Highway Bridges.

1.3.3.4. Excavations must allow for 12 inches [30 cm] of backfill between the bottom of the tank and the bottom of the excavation or the top of the anchor slab (or any other stabilizing materials used).

1.3.3.5. If either an anchor slab or other stabilizing material is used, allow additional depth in the excavation to accommodate their construction.

1.3.3.6. Typically, no additional depth of bedding is required for the use of a deadman anchoring system.

1.3.4. DEPTH OF COVER

⚠ CAUTION

In both traffic and nontraffic installations, no truck or equipment loads are allowed over the tank until the backfill is at least at the depth of cover specified in Table 1-1 or Table 1-2, whichever is applicable. Failure to follow this caution could result in minor or moderate injury, and/or damage to the tank.

1.3.4.1. We recommend that every site be thoroughly evaluated for the potential of a rise in the local water table or of trapped water (a wet-hole condition). Sufficient overburden and/or an appropriate anchoring system must be present to offset buoyancy of the tank in such conditions.

NOTICE

Failure to provide sufficient overburden and/or an appropriate anchoring system could cause tank failure, or could result in damage to the tank and/or surrounding property.

1.3.4.2. The tank owner or the owner's technical representative is responsible for determining sufficient overburden and/or appropriate anchoring system.

1.3.4.3. The minimum depths of cover dimensions given here are important to the successful installation of a tank. They may not be sufficient to counteract buoyancy in wet-hole conditions.

1.3.4.4. Additional depths of cover may be necessary due to safety requirements or operational requirements by governmental agencies.

⚠ WARNING

In a nontraffic installation, ensure that the area above the tank is not subjected to traffic or other types of loads, which could cause damage to the tank, and could result in death or serious injury.

I.3.4.5. Fuel tanks must have a cover depth as shown in Table I-1.

I.3.4.6. For fuel tanks, as a minimum, tank owner must comply with relevant fire codes—in the US, National Fire Protection Association (NFPA) 30 and 31; and in Canada, the National Fire Code of Canada and/or applicable local codes for fuel tanks. See Table I-1 for those requirements.

Table I-1
Depth of Cover Minimum Requirements for Fuel Tanks
No Traffic Options (US Installations) <ul style="list-style-type: none">• 24" [60 cm] backfill• 12" [30 cm] backfill + 4" [10 cm] reinforced concrete• 12" [30 cm] backfill + 6" [15 cm] asphalt
No Traffic Options (Canadian installations) <ul style="list-style-type: none">• 24" [60 cm] backfill
Traffic Options (US Installations) <ul style="list-style-type: none">• 36" [91 cm] backfill• 18" [46 cm] backfill + 6" [15 cm] reinforced concrete• 18" [46 cm] backfill + 8" [20 cm] asphalt
Traffic Options (Canadian installations) <ul style="list-style-type: none">• 39" [100 cm] backfill• 18" [46 cm] backfill + 6" [15 cm] reinforced concrete• 18" [46 cm] backfill + 8" [20 cm] unreinforced concrete
NOTE: These are NFPA 30 and 31 and National Fire Code of Canada requirements.

I.3.4.7. Tanks other than fuel tanks must have a cover depth as shown in Table I-2.

Table I-2
Depth of Cover Minimum Requirements for Tanks Other Than Fuel
No Traffic Options (All Installations) <ul style="list-style-type: none">• 12" [30 cm] backfill
Traffic Options (All installations) <ul style="list-style-type: none">• 36" [91 cm] backfill• 18" [46 cm] backfill + 6" [15 cm] reinforced concrete• 18" [46 cm] backfill + 8" [20 cm] asphalt

I.3.4.8. The maximum burial depth for standard tanks is 7 feet [2.1 meters] of cover over the top of the tank. However, tanks can be designed for a deeper burial.

I.3.4.9. You must obtain prior written authorization from us to deviate from a standard tank's maximum burial depth.

I.3.4.10. Call your sales representative prior to tank purchase for additional information if the burial depth is to be greater than 7 feet [2.1 meters].

I.3.4.11. If you are in the process of installing a tank and need to consider a deeper burial than the one given for the tank that was ordered, contact technical support (eng.support@zcl.com) to discuss available options.

I.3.4.12. If a surface pad is used, surface pads must extend a minimum of 12 inches [30 cm] beyond the tank in all directions.

I.3.4.13. If there is an unattached riser, it must not transmit load from the concrete slab to the tank. A minimum space of 6 inches [15 cm] is required between the bottom of the riser and the top of the tank.

I.3.4.14. Traffic loads from the top slab must not be transmitted to a containment sump or a riser. A minimum space of 3 inches [7.6 cm] is required between the riser or sump and the slab.

I.3.5. TANK SPACING

NOTE: In certain excavations with unstable soil, where shoring is permanently in place, the excavation might be classified as a stable-soil excavation. The tank owner should have a qualified engineer certify that the excavation would remain stable for the expected life of the tank installation.

I.3.5.1. GENERAL

I.3.5.1.1. The following are minimum spacings and must be increased as needed to accommodate deadmen or anchor slabs.

I.3.5.1.2. Always provide sufficient clearance to allow the deadmen to be set outside of the tank "shadow." See Figure I-2.

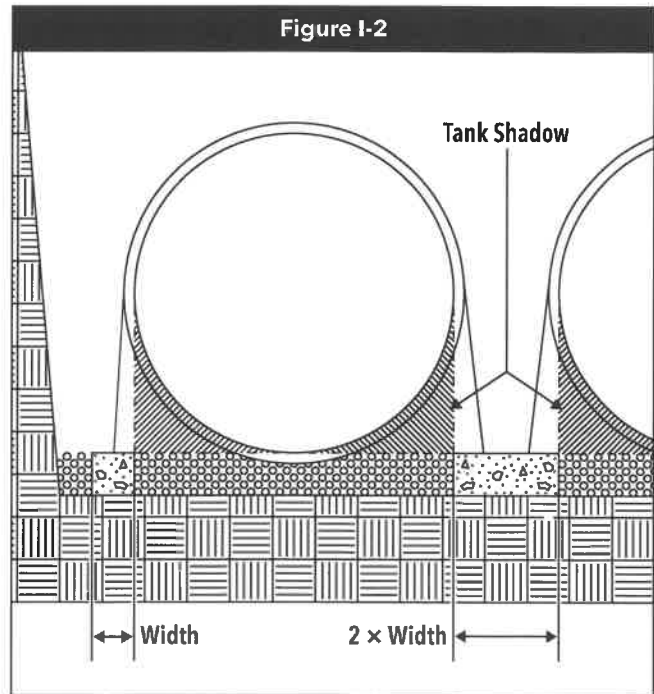

I.3.5.2. SPACING IN STABLE IN-SITU (NATIVE) SOIL CONDITIONS

I.3.5.2.1. The minimum spacing between the sidewall or endcap of the tank and the side of the excavation must be 18 inches [46 cm]. See **Figure 1-3**.

NOTE: All measurements from the tank sidewalls are to be taken from the outside diameter of the tank ribs.

I.3.5.2.2. If two or more tanks are installed in the same hole, allow for at least 18 inches [46 cm] between the tanks. In Canada, the National Fire Code of Canada requires 24 inches [60 cm] between a fuel tank and another tank or structure. See **Figure 1-3**.

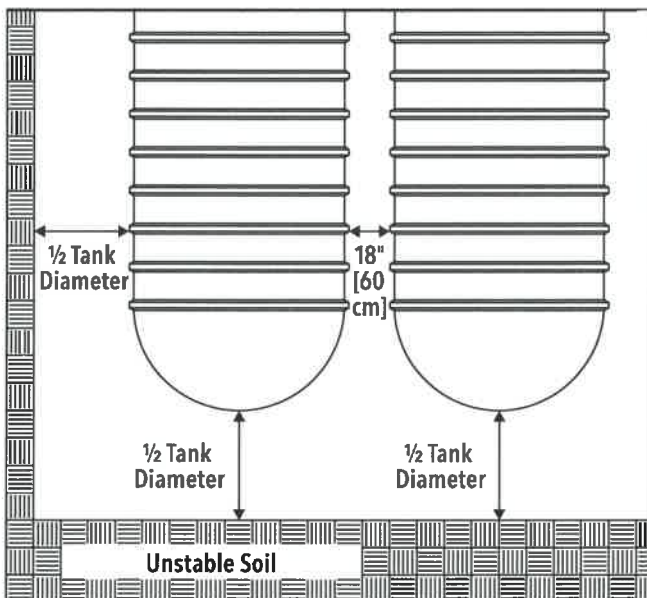
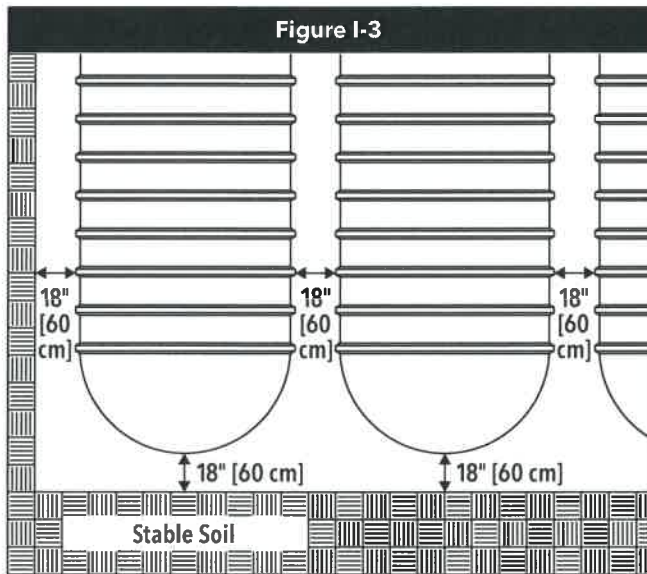

I.3.5.2.3. If two or more tanks are installed in the same hole and deadmen are used, the space between the tanks must be equal to or greater than two times the width of the deadman or deadmen required between the tanks. See **Figure 1-2**.

- The space between tanks using our deadmen is typically 36 inches [91 cm] for 10-foot- and 12-foot-diameter tanks, and 24 inches [60 cm] for tanks smaller than 10 feet in diameter.

I.3.5.3. SPACING IN UNSTABLE IN-SITU (NATIVE) SOIL CONDITIONS

I.3.5.3.1. We recommend that the tank owner seek the advice of a local foundation professional engineer if the in-situ soil is soft or inherently unstable (for example, peat, quick-sand, muck, landfill, soft or highly expansive clay, underground stream, etc.), as further described in **point 1.3.5.3.2**.

I.3.5.3.2. The excavation must allow a minimum space equal to 1/2 the diameter of the tank between the excavation wall and both the side and the endcap of the tank to enhance lateral resistance (see **Figure 1-3**), if one of the following criteria is met:

- the soil is cohesive soil that is less than 750 lbs./sq. ft. [35.9 kPa] as calculated from an unconfined compression test OR
- the soil has an ultimate bearing capacity of less than 3,500 lbs./sq. ft. [167.6 kPa]

I.3.5.3.3. Stabilizing materials, such as a reinforced concrete slab, may be required under the tank as a foundation in addition to the required 12-inch [30-cm] bedding in an excavation where the bottom is unstable.

I.3.5.3.4. The spacing between adjacent tanks is to be at least 18 inches [46 cm]. In Canada, the National Fire Code of Canada requires 24 inches [60 cm] between a fuel tank and another tank or structure. See **Figure 1-3**.

I.3.5.3.5. If deadmen are used, follow the spacing requirements between the tanks given in **points 1.3.5.2.2** and **1.3.5.2.3**.

I.3.6. ADDING TANKS AT EXISTING LOCATIONS

I.3.6.1. GENERAL

I.3.6.1.1. Additional tanks may be installed at existing locations if proper foundation support exists.

I.3.6.1.2. Backfill support around the existing tanks must not be disturbed.

I.3.6.1.3. It is the responsibility of the tank owner to choose the method of installation.

I.3.6.1.4. We recommend that one of the following methods be used.

I.3.6.2. PREFERRED METHOD

I.3.6.2.1. The preferred method is to install new tank(s) in a separate hole if space allows and/or if existing tank(s) must remain in service during installation of the new tank(s). The preferred method is described here (see **Figure 1-4**):

- install a new tank in a separate hole at least 3 feet [90 cm] from the original hole
- follow procedures outlined in the Installation Manual
- maintain the natural barrier of undisturbed soil between tanks
- see **section 1.3.5** for minimum spacing requirements between tanks
- sufficient soil must remain between the excavations so that the backfill in the original excavation does not shift.

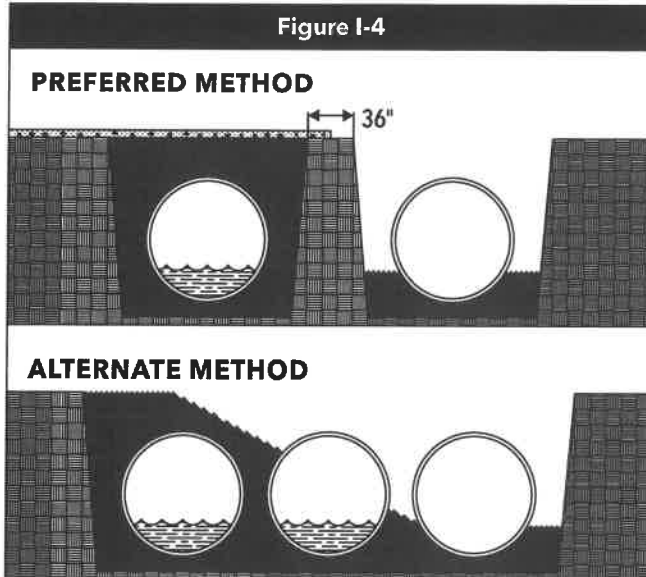

I.3.6.3. ALTERNATE METHOD

⚠ WARNING

Failure to shore tanks if necessary to keep the existing tank(s) from moving could result in death or serious injury.

⚠ CAUTION

If any existing tank(s) should move during the installation of new tanks, they must be removed and reinstalled according to the tank manufacturer's instructions. Failure to follow this caution could result in minor or moderate injury.

I.3.6.3.1. If the preferred method outlined above is not possible or practical, use the alternate method described here to bury additional tanks in the same installation hole (see **Figure 1-4**):

- Empty existing tanks to less than 1/4 of capacity.
- Remove the surface slab.
- Enlarge the excavation for the new tanks, but leave as much backfill as possible around the existing tanks.
- Install shoring, if necessary, to make sure that existing tanks do not move and that sufficient backfill remains around them.
- Follow the procedures and requirements for installing the tanks as outlined in this Installation Manual.
- See **section 1.2** for backfill requirements, and see **section 1.3** for excavation and spacing requirements.

I.3.7. ANCHORING TANKS

I.3.7.1. GENERAL

I.3.7.1.1. The tank owner or the owner's technical representative is responsible for determining an appropriate anchoring system.

I.3.7.1.2. We recommend that every site be thoroughly evaluated for the potential of a rise in the local water table or of trapped water (a wet-hole condition). Sufficient overburden and/or an appropriate anchoring system must be present to offset buoyancy of the tank in such conditions.

NOTICE

Failure to provide sufficient overburden and/or an appropriate anchoring system could cause tank failure, or could result in damage to the tank and/or surrounding property.

I.3.7.2. ANCHOR STRAPS

GENERAL

I.3.7.2.1. Only our anchor straps may be used when anchoring our tank.

I.3.7.2.2. We have the following anchor strap models:

- D-ring/D-ring anchor straps
- man-out-of-hole (MOH) straps
- hook/hook anchor straps (in Canada only)

NOTE: For information on the hook/hook anchor straps, refer to the Hook/Hook Anchor Straps Instructions supplement. See the Introduction for information on how to obtain this supplement.

I.3.7.2.3. Depending on which type of anchor strap is being used, see **section 1.3.7.2.7** (D-ring/D-ring) or **1.3.7.2.9** (MOH).

I.3.7.2.4. The locations for anchor straps on each tank are marked on the tank ribs by the arrowhead symbols ▶◀ (on the tank itself on 4-foot-diameter tanks).

I.3.7.2.5. When straps are placed over ribs, make sure that the area between the straps and the ribs is free of rocks or debris.

D-RING/D-RING ANCHOR STRAPS

I.3.7.2.6. Our D-ring/D-ring anchor straps are designed for anchoring our tanks.

I.3.7.2.7. While in the tank hole, the ends of the D-ring/D-ring anchor straps are connected to anchor points using hardware described in **section 1.3.7.3**.

MAN-OUT-OF-HOLE (MOH) STRAPS

I.3.7.2.8. The man-out-of-hole (MOH) straps system is designed for use in installations where water is in the excavation and/or where personnel may not enter the tank hole.

I.3.7.2.9. The MOH strap consists of two identical halves.

I.3.7.2.10. The ends of the MOH anchor straps are connected directly

to anchor points, and the two strap halves are connected to each other at the top of the tank. See **Figure 1-5**.

1.3.7.2.II. MOH anchor straps are to be installed in the following way:

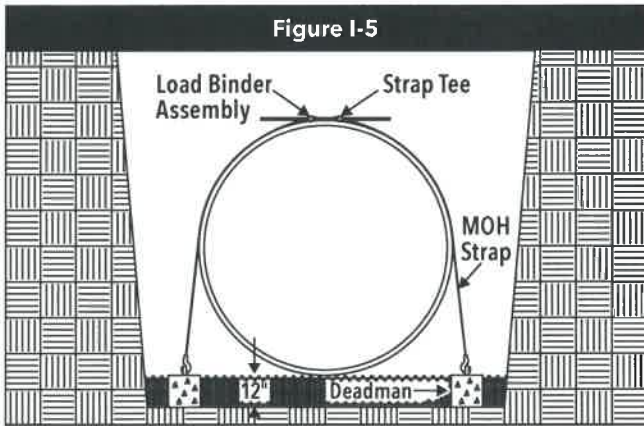

- lift the strap with the hook end down and the hook facing away from the tank
- lower the hook end of the strap between the tank and the anchor point, and hook the strap to the anchor point
- put a washer and a blind nut (acorn nut) on one end of the threaded rod.
- Feed the rod through the hole in the strap-end connector
- put a washer and a nut on the other end of the threaded rod
- center the wear plate on the top center line of the marked ribs
- lower the threaded rod, washer and nut into the channel section on the strap-end connector, taking care to place the washer and nut on the outside of the connector
- hand-tighten the nuts

1.3.7.2.I2. Repeat the bulleted items in **1.3.7.2.12** for the second rod of the assembly.

1.3.7.2.I3. After the two threaded rods are placed, tighten the threaded rods, using a torque wrench to tighten to 25-30 foot-pounds, or until snug.

1.3.7.2.I4. Repeat the bulleted items in **1.3.7.2.12** for each of the load binder assemblies.

1.3.7.3. HARDWARE AND ANCHOR POINTS

1.3.7.3.I. When our anchoring hardware is not being used, the installing contractor is responsible for providing hardware and anchor points of sufficient size and strength for the tank being installed.

1.3.7.3.2. The particular configuration of hardware will be determined by the contractor, the owner or the owner's representative, but is to adhere to the following:

- Anchoring hardware must be manufactured to industry standards and dimensions, and sized according to **Table 1-3**.
- All exposed metal on the anchoring system must be coated or galvanized to protect against corrosion.
- If the hardware used is not provided by us, contact the hardware manufacturer or supplier for specific information on hardware and its use.

Table 1-3

Tank Diameter	Minimum Turnbuckle Diameter (by Type)			Minimum Wire Rope Diameter
	Hook	Jaw	Eye	
4-foot	3/4"	1/2"	1/2"	3/8"
6-foot	3/4"	1/2"	1/2"	3/8"
8-foot	1 1/4"	3/4"	3/4"	1/2"
10-foot	1 1/4"	3/4"	3/4"	1/2"
12-foot	1 1/4"	3/4"	3/4"	1/2"

1.3.7.3.3. When D-ring/D-ring straps are shipped and turnbuckles are ordered from us, we may ship extra hardware that may or may not be necessary with alternate deadmen placement.

1.3.7.3.4. Locate the anchor points as shown in **Figure 1-6** and **Table 1-4**. Refer to dimensions in **Table 1-4**. Align (within a tolerance of ±1 inch) all anchor points.

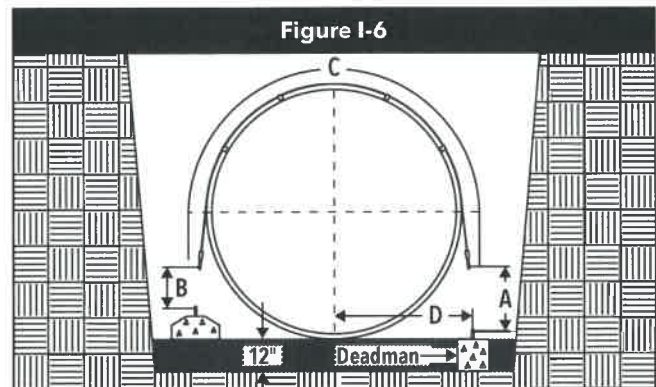
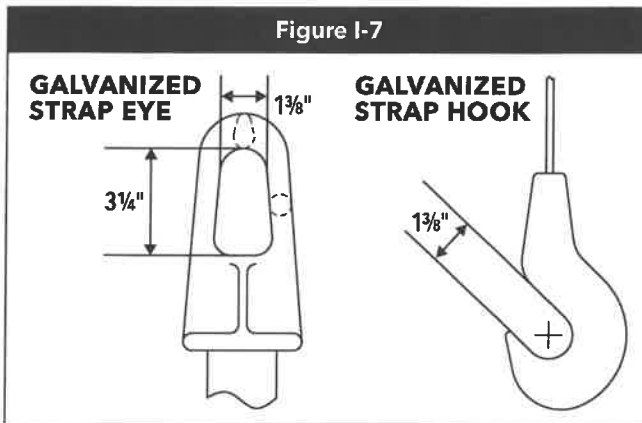

Table 1-4

Nominal Tank Diameter	A: Strap Eye To Anchor Point	B: Alternate Dimension	C: Strap Length	D: Center of Tank to Center of Deadmen
4-foot	10" [25 cm]	not recommended	100" [254 cm]	31" [79 cm]
6-foot	23" [58 cm]	not recommended	145" [368 cm]	43" [111 cm]
8-foot (Red Tank)	29" [74 cm]	17" [43 cm]	181" [460 cm]	53" [135 cm]
8-foot (Green Tank)	30" [76 cm]	18" [46 cm]	195" [495 cm]	57" [145 cm]
10-foot (Red Tank)	38" [97 cm]	26" [66 cm]	236" [600 cm]	70" [178 cm]
10-foot (Green Tank)	39" [100 cm]	27" [69 cm]	236" [600 cm]	71" [180 cm]
12-foot	46" [117 cm]	34" [86 cm]	271" [688 cm]	88" [224 cm]

NOTE: If a D-ring/D-ring strap is used on a 4-foot-diameter tank, the anchor point must be 3 inches below the top of the bedding.

I.3.7.3.5. Use only appropriately sized hardware with the strap eye. See **Figure 1-7** for dimensions of strap eye.



I.3.7.3.6. When connecting the end of an anchor strap to the anchor point, common methods are those shown in **Figure 1-8**: **A)** using a drop-forged turnbuckle, **B)** using a turnbuckle and turnbuckle extension, **C)** using the hook end of the strap, **D)** using a looped wire rope, **E)** using a combination of a drop-forged turnbuckle and a looped wire rope.

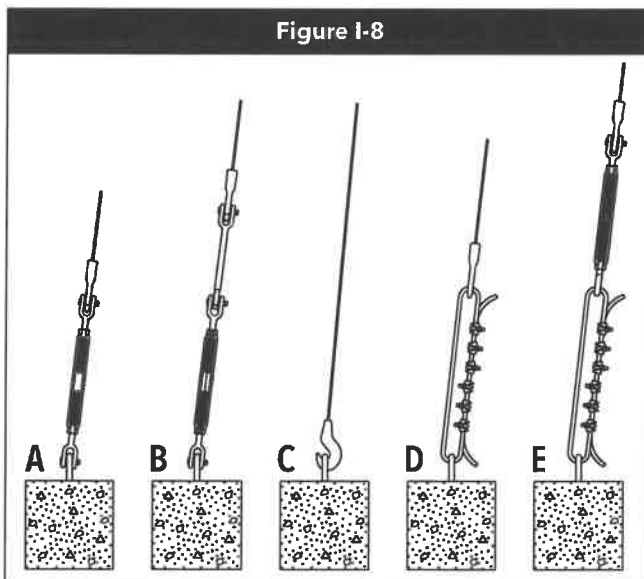

I.3.7.3.7. If using a wire rope, refer to recommendations of wire rope manufacturer and supplier, and follow accepted industry standards when selecting, using, attaching or connecting wire rope. See **Figure 1-8** and **Figure 1-9**.

I.3.7.3.8. The installer is responsible for using appropriate and approved engineering practices when fastening wire rope.

I.3.7.3.9. When fastening wire rope, use a minimum of 2 clips for a 3/8-inch [1-cm] wire rope and 3 clips for a 1/2-inch [1.3-cm] wire rope on each termination. See **Table 1-3** for minimum wire rope diameter.

I.3.7.3.10. Turn back from the thimble the exact amount of wire rope specified by the manufacturer of the clips used.

I.3.7.3.11. Apply the first clip at a distance from the dead end of the wire rope that is equal to the largest width of the clip used. See **Figure 1-9**.

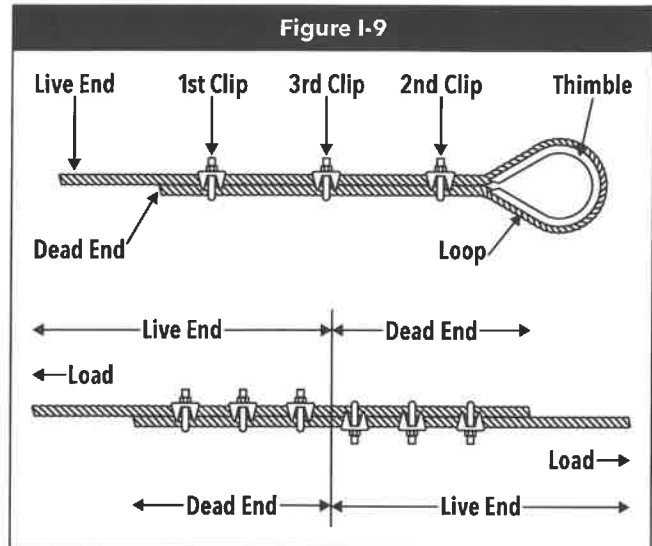

I.3.7.3.12. For each clip, apply a U-bolt over the dead end of the wire rope. See **Figure 1-9**.

NOTE: Live end rests in the saddle.

I.3.7.3.13. When only 2 clips are required, apply the second clip as close to the loop or thimble as possible. See **Figure 1-9**.

I.3.7.3.14. When more than 2 clips are required, apply the second clip as close to the loop or thimble as possible, turn nuts on the second clip firmly, but do not tighten initially. See **Figure 1-9**.

I.3.7.3.15. When more than 2 clips are required, space additional clips equally between the first 2, take up rope slack and tighten nuts on each U-bolt evenly.

I.3.7.3.16. Tighten all hardware uniformly and follow the manufacturer's torque specifications. Double-check the tightness once the anchoring system is complete.

I.3.7.3.17. If forming a loop in the wire rope, a splice is required for connecting the two ends together.

I.3.7.3.18. Standard rigging practice for splicing wire rope calls for using twice the number of clips recommended for a single-end termination.

I.3.7.3.19. Use a minimum of 4 clips for a 3/8-inch [1-cm] wire rope and a minimum of 6 clips for a 1/2-inch [1.3-cm] wire rope.

I.3.7.3.20. Place the rope ends parallel to each other and install the clips as shown in **Figure 1-9**.

I.3.7.4. DEADMEN

I.3.7.4.1. Deadmen help anchor tanks in installations in which there is potential for a high water table or trapped water.

I.3.7.4.2. A deadman is typically a reinforced concrete beam and should be designed according to the applicable American Concrete Institute code or the applicable Canadian Standards Association (CSA) standard, whichever is relevant.

I.3.7.4.3. We recommend that you use one of our strap systems with our factory-supplied deadmen.

I.3.7.4.4. When installing any size tank, and when using our D-ring/D-ring anchor straps and prefabricated deadmen, the deadmen are to be placed so that their tops are even with the bottom of the tank. See **Figure 1-6** and **Table 1-4** for anchor-point dimensions when using our deadmen.

- For 8-foot-, 10-foot- and 12-foot-diameter tanks, an option when using D-ring/D-ring straps is to place the deadmen on the bedding so the bottoms of the deadmen are even with the bottom of the tank.
- This is not recommended for 4-foot- and 6-foot-diameter tanks.

I.3.7.4.5. The width and thickness of a deadman depends on the following:

- tank diameter
- water-table elevation
- number of containment sumps
- burial depth

I.3.7.4.6. The total length of a deadman (on each side of the tank) is typically equal to the length of the tank.

- Our prefabricated deadmen come in various lengths.
- Deadmen are to be butted together end to end on each side of the tank when multiple sections are used.
- Depending on the installation, multiple deadmen may be required and are to adhere to the following:
 - The total length of the assembled deadmen must be appropriate for the installed tank.
 - Each section of assembled deadmen must contain at least two balanced anchor points.
 - An equal number of deadmen is required on both sides of the tank.
- Our prefabricated deadmen are supplied with 3/4-inch-diameter galvanized adjustable anchor points (subsequently referred to as anchor points). See **Figure 1-10**.
 - These anchor points protrude up through the slots in the deadmen and are temporarily supported with cotter pins.

⚠ WARNING

Only use the anchor points when lifting and positioning the deadmen. A spreader bar may be required to lift longer sections of deadmen. Use guide ropes to guide the deadmen when lifting. Failure to do so could result in death or serious injury.

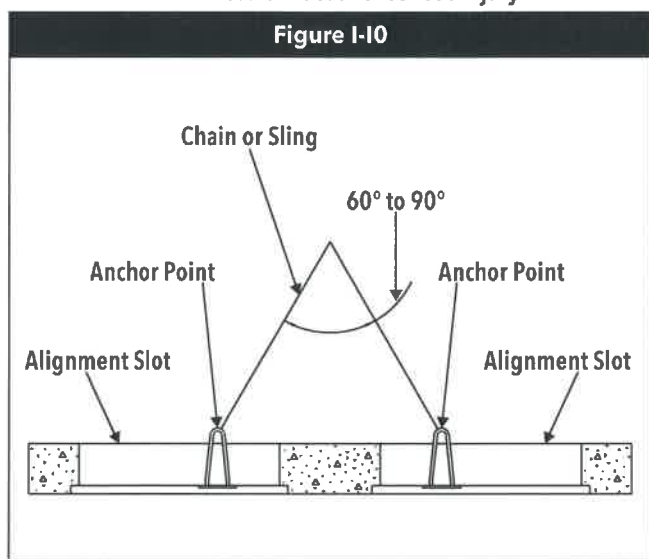

I.3.7.4.7. See **Table 1-5** for typical deadmen dimensions for tanks (other than 10-foot-diameter tanks with a capacity greater than 25,000 gallons [95,000 liters], given the following scenario:

- an empty tank
- a 3-foot [91-cm] burial depth
- groundwater to grade
- 1 containment sump

Tank Diameter	Typical Deadmen Dimensions (Width x Depth)
6-foot	12" [30 cm] × 12" [30 cm]
8-foot	12" [30 cm] × 12" [30 cm]
10-foot	18" [46 cm] × 9" [23 cm]
12-foot	36" [91 cm] × 8" [20 cm]

I.3.7.4.8. Tanks with more than 1 containment sump and 10-foot-diameter tanks with a capacity greater than 25,000 gallons [95,000 liters] may require either a deeper burial or deadmen larger than those shown in **Table 1-5**. Contact technical support (eng.support@zcl.com) for further information.

I.3.7.4.9. The minimum spacing between tanks must be increased to accommodate deadmen.

I.3.7.4.10. Always provide sufficient clearance to allow the deadmen to be set outside the tank "shadow." See **section 1.3.5** for tank spacing information.

I.3.7.4.11. For placement of prefabricated deadmen, see **Figure 1-2**.

I.3.7.4.12. Some contractors use the deadmen as a construction guide for proper depth of bedding.

I.3.7.4.13. If our prefabricated 18-inch- [45 cm] wide low-profile deadmen are used as a construction guide, they may need to be elevated. This can be accomplished by putting 3 1/2 inches [9 cm] of backfill or a 4×4 piece of wood (or equivalent) underneath so that the top of the deadmen is 12 inches [30 cm] off of the bottom of the excavation. See **Figure 1-11**.

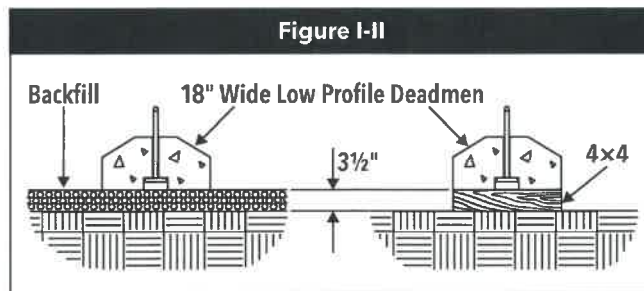

NOTE: Low-profile deadmen are not 12 inches [30 cm] high.

I.3.7.5. TURNBUCKLES

I.3.7.5.1. We also offer a turnbuckle that will connect the deadman anchor point to the FRP anchor strap. See **Figure 1-8**. When the deadman is properly positioned, this will eliminate the use of wire rope. See **section 1.3.7.2** for more detail on anchor straps.

I.3.7.6. ANCHOR SLABS

NOTE: The tank owner is responsible for the design of anchor slabs.

I.3.7.6.1. An anchor slab is a reinforced concrete base and should be designed according to the applicable American Concrete Institute code or the applicable Canadian Standards Association (CSA) standard, whichever is relevant.

I.3.7.6.2. The total length of the slab must be at least the same as the length of the tank.

I.3.7.6.3. The minimum slab thickness is 8 inches [20 cm].

I.3.7.6.4. The width of the slab depends on the tank diameter. The slab must extend a minimum of 18 inches [46 cm] (12 inches [30 cm] for 4-foot-diameter tanks) beyond each side of the tank.

I.3.7.6.5. Provide a separate anchor point for each anchor strap.

I.3.7.6.6. All anchor points must be engineered to withstand the tank's buoyancy forces.

I.3.7.6.7. Refer to **Figure 1-12** for anchor-point height. Refer to **Table 1-4** for other anchor-point dimensions.

I.3.7.6.8. When using a concrete anchor slab, allow sufficient depth in the excavation for 12 inches [30 cm] of bedding material between the tank and the anchor slab. See **Figure 1-12**.

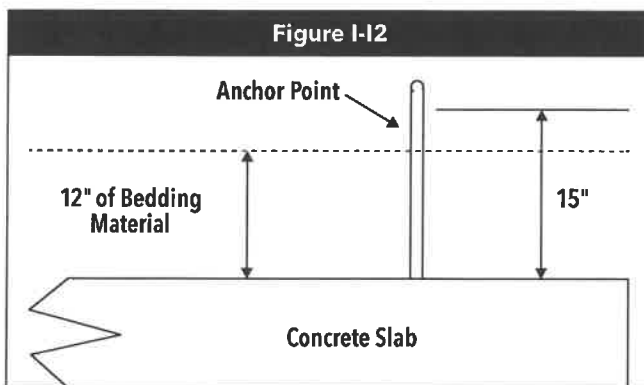

I.3.7.6.9. When using our straps and turnbuckles, anchor points must extend at least 3 inches [7.6 cm] above the bedding. With a 12-inch [30-cm] bedding, the anchor point is 15 inches [38 cm] above the slab.

I.3.7.7. TAKING DIAMETER MEASUREMENTS

GENERAL

I.3.7.7.1. Diameter measurements must be taken at various stages of the installation process to verify that the process is proceeding correctly.

I.3.7.7.2. It is important that these measurements are taken and, if needed, appropriate action is taken so that tank deflection is within allowable limits.

I.3.7.7.3. Diameter measurements of the tank must be taken at one or more locations on each tank or tank compartment. It is preferable to take the measurement near the center of a tank or compartment if possible.

I.3.7.7.4. An initial measurement must be taken before installation of the tank begins. This first measurement is used as a comparison reference for subsequent measurements in order to check proper backfill placement.

I.3.7.7.5. Additional measurements must be taken:

- after applying anchor straps (if used)
- after backfilling is brought to the top of the tank
- after backfilling is brought to subgrade

I.3.7.7.6. Described here are two methods using a dipstick to measure the internal diameter of the tank—one not using a standpipe and one using a standpipe.

I.3.7.7.7. Similar methods can be used, such as using a tape measure, for example.

I.3.7.7.8. Both methods for taking deflection measurements will give the same result.

I.3.7.7.9. For both methods, drive a small-headed, nonsparking nail (for example, brass) halfway into a wooden dipstick 1 inch [2 cm] above its base.

DIAMETER MEASUREMENT WITHOUT A STANDPIPE

I.3.7.7.10. Place the dipstick into a service fitting.

I.3.7.7.11. Measure the distance from the tank bottom to the top of the fitting and record this measurement.

I.3.7.7.12. Pull the dipstick up until the exposed nail catches on the inside top of the tank.

I.3.7.7.13. Measure the distance from the tank top (inside) to the top of the fitting. Subtract the distance from the nail to the base of the dipstick and record this measurement.

I.3.7.7.14. Subtract the second measurement (inside tank top to top of fitting) from the first measurement (tank bottom to top of fitting) to calculate the diameter measurement.

I.3.7.7.15. Record this diameter measurement at the appropriate place (as Measurement #1, #2, #3 or #4) on the Tank Installation Checklist.

DIAMETER MEASUREMENT WITH A STANDPIPE

I.3.7.7.16. Place the dipstick into a service fitting with a standpipe.

I.3.7.7.17. Measure the distance from the tank bottom to the top of the standpipe and record this measurement.

I.3.7.7.18. Pull the dipstick up until the nail catches on the inside top of the tank.

I.3.7.7.19. Measure the distance from the tank top (inside) to the top of the standpipe. Subtract the distance from the nail to the base of the dipstick and record this measurement.

I.3.7.7.20. Subtract the second measurement (inside tank top to top of standpipe) from the first measurement (tank bottom to top of standpipe) to calculate the deflection.

I.3.7.7.21. Record the deflection at the appropriate place (as Measurement #1, #2, #3 or #4) on the Tank Installation Checklist.

CALCULATION AND COMPARISON

I.3.7.7.22. To calculate the deflection at any time during installation, take a diameter measurement and subtract it from Measurement #1.

I.3.7.7.23. Compare this calculated deflection to the applicable allowable deflection shown in Table 1-6.

Tank Diameter	Allowable Deflection
4-foot	½" [1.3 cm]
6-foot	¾" [1.9 cm]
8-foot	1⅛" [2.9 cm]
10-foot	1½" [3.8 cm]
12-foot	1¾" [4.5 cm]

I.3.7.7.24. Deflection above the allowable limit indicates the tank is not properly installed.

I.3.7.8. ONSITE PRESSURE TESTING REQUIREMENTS

I.3.7.8.1. At various stages of the installation process, there may be onsite testing requirements.

I.3.7.8.2. To pressure test tanks, you need to construct a test manifold. See Figure 4-1.

- The pressure-supply gauge must have a maximum full-scale reading of 15 psig [100 kPa].
- The pressure-relief device must be rated to a maximum of 6 psig [40 kPa], or 4 psig [28 kPa] for a 12-foot-diameter tank, to reduce the risk of overpressurizing the tank.

NOTE: For multicompart ment tanks, you need a test manifold for each compartment.

2: HANDLING AND STORING TANKS

2.1. GENERAL

2.1.1. Take care not to drop or damage the tank during loading, unloading, handling and storage at the jobsite.

2.1.2. Move tanks by lifting and setting only. Do not move tanks by rolling or dragging.

2.1.3. Always lift tanks by using the lifting lugs provided with the tank. Distribute the lifting load evenly between the lifting lugs. Use spreader bars and equal length slings as required.

NOTE: Larger tanks may be provided with guide lugs for attachment of guide ropes during lifting and positioning operations. Do not use guide lugs for lifting.

NOTICE

Never roll, drag or drop the tank. This could result in damage to the tank.

2.2. UNLOADING, HOISTING AND GUIDING TANKS

2.2.1. Complete the following steps before unloading or relocating the tank on the jobsite (and before preinstallation testing at the jobsite):

- Visually inspect the entire exterior surface of the tank to make sure that no shipping or handling damage has occurred. Look particularly for visible damage, cracks or deep scrapes.
- Sign the shipping papers accepting the tank as delivered. Any damage observed must be noted in these papers.
- Be sure that all equipment used to lift the tank is rated to handle the load. See **Appendices B1, B2 and B3** in this Installation Manual for weights.
- Select a smooth, solid, level area on which to place the tank, and clear that area of all large rocks, trash and debris.
- Make sure all tools and other items that may damage the tank during unloading are removed from the trailer bed.

2.2.2. Make sure the tank is secured in such a way that it does not roll off the truck when unloading the tank from the truck.

⚠ WARNING

Do not release straps securing the tank to the truck until lifting equipment (such as a crane) is secured to the tank's lifting lug(s) and until anyone in a position to be injured by the tank's movement is in a safe location. Failure to do so could result in death, serious injury or property damage.

⚠ WARNING

Always secure the tank before moving, rotating or lifting it. This is commonly done by connecting a crane or backhoe to the lifting lugs. Failure to follow this warning could result in death or serious injury.

⚠ WARNING

While moving or lifting the tank, do not position any part of your body underneath the tank. Failure to follow this warning could result in death or serious injury.

2.2.3. When hoisting and guiding the tank, see **Figures 2-1** and **2-2**, and follow these instructions:

- choose suitable lifting sling(s) for the tank being installed
- when using multiple lifting lugs, the angle of the lifting sling should never exceed 30 degrees from vertical—see **Figure 2-1**
- when the tank is shipped upright, use all lifting lugs to unload and install the tank—see **Figure 2-2**
- some tanks are rotated on the truck for shipping purposes. These tanks have extra lifting lug(s) to aid in the loading/unloading process—see **Figure 2-2**
- use the lifting lugs that are situated on top of the tank in its rotated position to offload the tank from the truck and place it on the ground.
- to install the tank, once it has been placed on the ground, carefully rotate the tank to its upright position and then use all lifting lugs situated on top of the tank in its upright position—see **Figure 2-2**

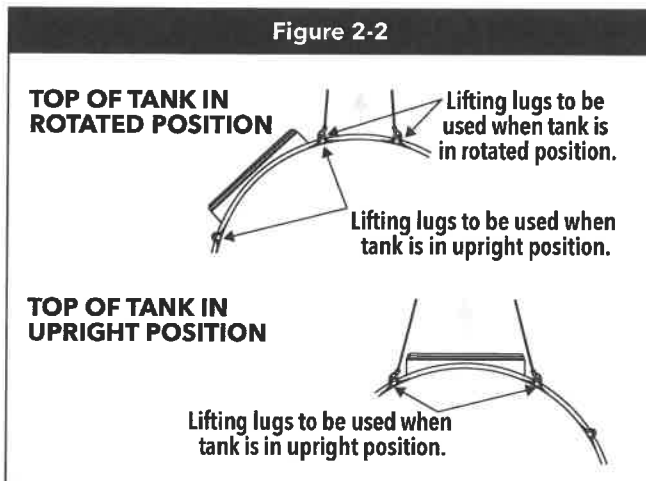
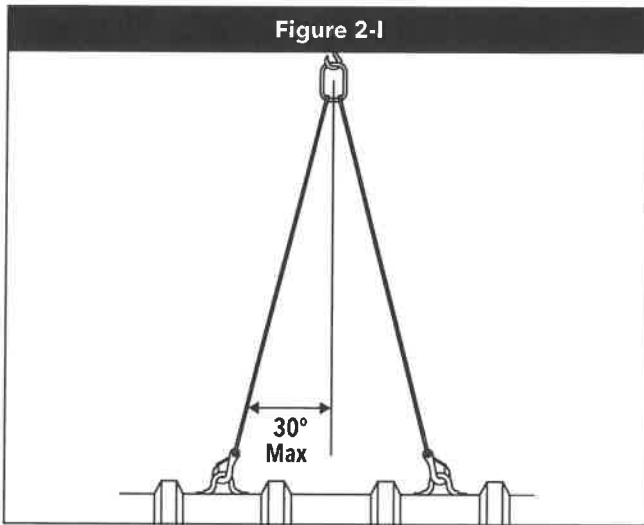

2.2.4. Do not wrap chain or cable around the tank at any time, including when securing the tank on the ground.

2.2.5. Use guide ropes to guide the tank when needed.

⚠ WARNING

Do not use guide lugs for lifting. Failure to follow this warning could result in death, serious injury or property damage.

2.2.6. When handling a tank with a bottom sump or fitting, always take extra care so that the bottom sump or fitting is not damaged by contact with any other object, such as the truck bed or the ground.

2.3. STORING TANKS

2.3.1. Whenever a tank is temporarily placed above the ground at the site, place it on a smooth, solid, level area that is clear of large rocks, trash and debris, and then chock it in place to prevent rolling.

⚠ WARNING

Always chock the tank. The tank is heavy and has a large surface area. The tank will roll on sloped surfaces and could be blown about by the wind. Movement of the tank could result in death or serious injury.

2.3.2. Tie the tank down if high winds are expected. Do not use wire rope or chains. Doing so could damage the tank.

2.3.3. Never place tie-down straps over collars, reservoirs or access openings.

2.3.4. Whenever a tank is temporarily placed above the ground at the site, always take extra care so water does not enter the collar. We recommend that the tank be rotated and/or the collar covered.

2.3.5. Ensure that the tank is UV-protected if it will be stored above the ground for an extended period of time, typically 12 months depending on the geographic location of the installation.

NOTICE

If water enters the collar, it could freeze and could result in damage to the tank and/or collar.

3: PREINSTALLATION INSPECTION AND TESTING

3.1. GENERAL

⚠ WARNING

Do not conduct preinstallation testing while the tank is on a trailer. Failure to follow this warning could result in death or serious injury.

NOTICE

Do not put product in the tank until all necessary preinstallation inspection and testing is completed. Failure to follow this notice could result in property damage

3.1.1. The applicable inspection and testing procedures in **sections 3** and **4** must be performed to validate the applicable limited warranty.

3.1.2. All tanks are tested and inspected at the factory prior to shipment. However, in order to verify the absence of any damage resulting from shipping or handling, prior to installation all tanks must also be inspected at the site. Some tanks must also be tested at the site prior to installation according to the applicable procedures.

⚠ WARNING

Do not lift or hoist a tank under pressure. Failure to follow this warning could result in death or serious injury.

3.1.3. Not all tanks are pressure-testable in the field. We recommend the pressure test on any tank that can be safely sealed for testing. See **section 4** for pressure-test instructions. If a tank needs to be hydrostatically tested, see **section 4** and follow those instructions.

3.1.4. If the tank is a water/wastewater tank equipped for optional preinstallation testing, after inspecting the tank (see **section 3.2**), follow procedures in the Preinstallation Testing Instructions for Water/Wastewater Tanks Factory-Equipped for Pressure Testing. See the **Introduction** for information on how to obtain this supplement.

3.1.5. If damage of any kind is detected, contact the manufacturing facility that shipped the tank before installing the tank.

NOTE: Do not attempt unauthorized repairs.

3.2. INSPECTING THE TANK

3.2.1. Thoroughly inspect the entire outside surface of the tank for signs of shipping or handling damage. Rotate or lift the tank to inspect the bottom of the tank.

3.2.2. If damage of any kind is detected, contact the manufacturing facility that shipped the tank before installing the tank.

NOTE: Do not attempt unauthorized repairs.

4: TESTING DURING INSTALLATION

4.1. TANK TYPES

4.1.1. Typically, all underground storage tanks need to be tested in the field to confirm that there are no problems with the tank. We recommend the pressure test on any tank that can be safely sealed for testing. Tanks that cannot be sealed, including those with large access openings or with pipe nozzles, may be tested hydrostatically if required.

4.1.2. We recommend that the following tanks we manufacture are pressure tested during installation:

- fuel tanks
- DEF tanks
- chemical tanks
- potable water tanks
- oil/water separators
- pipeline sump tanks

4.1.3. All UL-label, ULC-label and potable water tanks must be pressure tested after backfill is brought close to the top of the tank.

4.1.4. Tanks that cannot be sealed and are not equipped for pressure testing may require hydrostatic testing. They include the following:

- water tanks
- wastewater tanks

4.2. PRESSURE-TEST PRETESTING PROCEDURES

NOTICE

Do not install any piping or fittings other than test fittings until all preinstallation testing has been completed. Failure to follow this notice could result in property damage.

NOTICE

Never pressurize a wet interstitial space. Doing so could result in damage to the primary tank and/or tank failure.

4.2.1. Someone must be with the tank at all times during pressure testing.

4.2.2. Prior to the pressure test, remove all plugs, apply sealant, and replace and tighten plugs.

⚠ WARNING

Before beginning the pressure test, notify all people on the test site to remain in a safe location. **NEVER LEAVE A TANK UNDER PRESSURE UNATTENDED.** Stand clear of manways, fittings and tank ends during the test. When the tank is under pressure, the manways, access openings and/or fittings may dislodge, or the tank could rupture, and this could result in death or serious injury.

4.2.3. If the tank being installed is not a pressure-testable tank, proceed to **section 5**.

4.3. PREPARING THE TANK FOR PRESSURE TESTING

4.3.1. The pressure test pressure for 4-foot-diameter through 10-foot-diameter tanks is 5 psig [35 kPa], and 3 psig [21 kPa] for 12-foot-diameter tanks.

⚠ WARNING

Do not overpressurize the tank. Position the pressure gauges so that the pressure readings can be clearly read at all times. The pressure gauge must have a pressure-relief valve that is used and set at 6 psig [40 kPa] (4 psig [28 kPa] for 12-foot-diameter tanks). Failure to follow this warning could result in death or serious injury.

4.3.2. The tester is responsible for verifying that all of the test equipment is in good working condition, and is properly configured and calibrated.

4.3.3. Construct a test manifold with two pressure gauges as shown in **Figure 4-1**. Each pressure gauge must have a maximum full-scale reading of 15 psig [100 kPa] with graduations in ½ psig [2.5 kPa] increments, and a pressure-relief valve set at 6 psig [40 kPa] (4 psig [28 kPa] for 12-foot-diameter tanks).

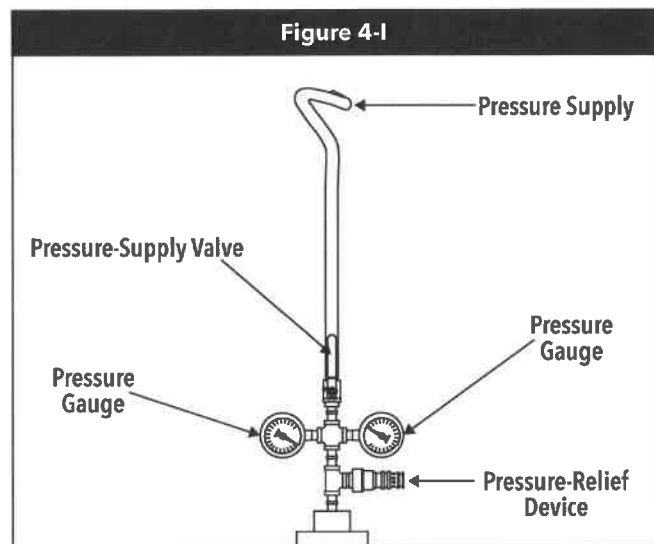

4.3.4. Take particular care to note the following:

- An interstitial test manifold is needed for testing the dry interstitial space of a pressure-testable double-wall tank. See **Figure 4-2**.
- A test manifold is not required for testing a tank interstice filled with monitoring fluid.
- All compartments of a multicompart tank may be tested simultaneously, or each compartment may be tested separately.
- When pressure testing multicompart tanks, a test manifold is needed for each compartment.

4.3.5. During pressure tests, ambient air temperature can affect pressure-gauge readings.

4.3.6. When testing tanks with wet monitoring, remove the reservoir fitting plug.

4.3.7. If the tank has threaded fittings, the installer is responsible for selecting a thread sealant that is compatible with the product being stored. Some sealants cannot be used with some stored products.

4.3.8. Remove factory-supplied temporary plugs and install permanent plugs in all openings where piping will not be installed.

4.3.9. Make sure all manway bolts or flange bolts are torqued to 25 ft-lb [34 N-m], and fitting plugs are properly doped and sealed.

4.3.10. The tank may be pressure tested with the factory-supplied temporary plugs. Redope and tighten temporary plugs if needed.

4.3.11. Keep one service fitting open in each compartment for the test manifold.

4.3.12. Tanks equipped with flanged nozzles may require contractor-supplied blind flanges for preinstallation pressure testing.

4.4. PRESSURIZING THE PRIMARY TANK

4.4.1. Install the test manifold in the open service fitting and connect the pressure source to the test manifold.

4.4.2. If the interstitial space is dry, close the valve on the interstitial test manifold before pressurizing the primary tank.

4.4.3. Open the pressure-supply valve and pressurize the primary tank to 5 psig [35 kPa] (3 psig [21 kPa] for 12-foot-diameter tanks). Allow a few minutes for the temperature in the tank to stabilize, then allow the pressure to stabilize by adding or removing pressure as necessary.

4.4.4. Close the valve on the primary tank test manifold and disconnect the pressure supply.

4.4.5. Hold and monitor the pressure for a minimum of 1 hour.

4.4.6. If the interstitial test manifold shows a pressure build-up in the interstitial space of a dry-monitor, double-wall tank, contact the manufacturing facility that shipped the tank.

NOTE: Do not attempt unauthorized repairs.

4.5. PRESSURIZING THE INTERSTITIAL SPACE IN A DRY TANK

⚠ WARNING

Never lift or hoist a tank under pressure. Failure to follow this warning could result in death or serious injury.

NOTE: Do not attempt unauthorized repairs.

4.5.1. Tanks with a dry interstitial space come with a quick-disconnect assembly that may be used as the interstitial test manifold. See **Figure 4-2**.

4.5.2. If the tank is not configured as shown in **Figure 4-2** prior to installation, contact the manufacturing facility that shipped the tank.

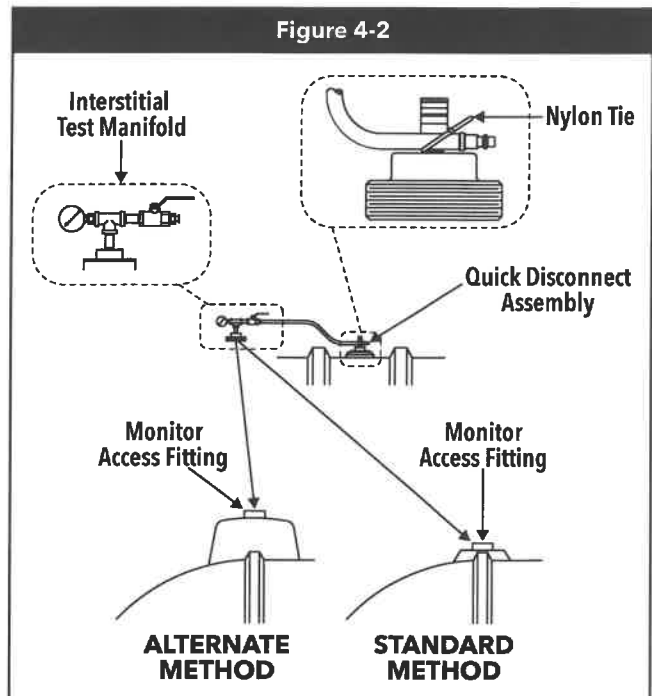

4.5.3. The quick-disconnect assembly must not be connected to the service fitting when pressure testing the primary tank. Keep the nylon tie in place.

4.5.4. Maintain the pressure in the primary tank.

NOTICE

Do not connect the pressure supply directly to the access fitting for interstitial-space monitoring. Pressurizing the secondary tank (interstitial space) by itself could damage the primary tank or cause tank failure.

4.5.5. Free the hose from the service fitting by cutting the nylon tie.

4.5.6. Insert the hose into the quick-disconnect fitting and open the valve to allow pressure to transfer from the primary tank to the interstitial space.

4.5.7. Reconnect the pressure-supply line. Allow the pressure to stabilize at 5 psig [35 kPa] (3 psig [21 kPa] for 12-foot-diameter tanks) by adding or removing pressure as necessary.

4.5.8. Close the pressure-supply valve on the test manifold and disconnect the pressure-supply line.

4.6. SOAPING THE TANK

4.6.1. After pressurizing the tank, soap the tank to check the tank's integrity.

- Soap either the fittings, manways and covers or the entire exterior of the tank, depending on what part of the testing process the tester is at and what kind of tank is being pressure tested. See **Pressure-Testing Sidebar** instructions for specific types of tanks.
- Watch for active bubbles. There should not be any.
- During freezing conditions, a suitable solution such as windshield washer fluid may be added to the soap and water mixture.

4.6.2. When doing a soap test, rotate the tank to check the bottom. Do not rotate a tank filled with monitoring fluid.

NOTE: Before rotating the tank, place protective material on the area on which the tank will be rotated. Make sure the area is flat and free of large or sharp objects, such as rocks, which may damage the tank.

4.6.3. Rotate the tank slowly and carefully to avoid developing too much momentum. Momentum can grow because manways and fittings on top of the tank make it top heavy.

NOTE: Make sure the tank's fittings and manways never touch the ground. Do not rotate the tank more than 120 degrees from the initial starting point.

4.6.4. If damage is detected, contact the manufacturing facility that shipped the tank.

NOTE: Do not attempt unauthorized repairs.

4.7. PERFORMING VISUAL CHECKS ON A TANK WITH A WET INTERSTITIAL SPACE

NOTICE

Never pressurize a wet interstitial space. Doing so could result in damage to the tank and/or tank failure.

NOTICE

Never rotate a tank filled with monitoring fluid. Doing so could result in damage to the tank and/or tank failure.

4.7.1. Check that the tank has monitoring fluid in the reservoir. Measure the level of the monitoring fluid in the reservoir and record on checklist.

NOTE: If the reservoir is less than 1/3 full, contact the manufacturing facility that shipped the tank. See the back cover of the Installation Manual for contact numbers.

4.7.2. Visually check both the interior and the exterior of the tank for monitoring fluid. (The monitoring fluid is dyed blue to distinguish between moisture and monitoring fluid.) There should not be any.

- Visually check the interior of the tank.
 - check each compartment of a multicompartment tank
- Visually check the exterior of the tank.
 - check the exterior of each compartment of a multicompartment tank
 - if monitoring fluid is found, wipe the tank dry and verify that the monitoring fluid does not reappear
 - lift the tank to check the bottom—do not roll the tank

NOTE: Tanks are shipped with a pop-off valve to ensure that excess pressure does not build in the interstitial space during shipping and/or storage. Conditions such as excess heat can cause this valve to release. If the tank is rotated and the ambient temperature is much higher than when it was shipped, the pop-off valve will relieve the pressure, which may result in monitoring fluid on the tank surface. If this occurs, wipe the tank dry and verify that the monitoring fluid does not reappear.

NOTE: If there is still monitoring fluid present on the tank after completing this process, contact the manufacturing facility that shipped the tank.

4.8. RELEASING PRESSURE FROM THE TANK

4.8.1. If there is an interstitial space to pressurize, open the valve of the interstitial test manifold and carefully release the pressure in the interstitial space first.

4.8.2. If the tank is a multicompartment tank, carefully release the pressure in the end compartments first.

4.8.3. Then carefully release the pressure from the base tank.

NOTICE

Never allow the pressure in the interstitial space to be greater than the pressure in a primary tank. Failure to follow this notice could result in damage to a primary tank and/or tank failure.

⚠ WARNING

Never remove the service-fitting plugs when there is pressure in the tank. Failure to follow this warning could result in death or serious injury.

4.8.4. Remove the test manifolds and replace the protective covers in the service fittings.

4.9. TESTING FOR SPECIFIC TYPES OF PRESSURE-TESTABLE TANKS

NOTE: When pressure testing a tank, follow the procedures outlined in Pressure-Testing Sidebar for the specific type of tank being installed.

4.9.1. GENERAL

4.9.1.1. Prepare the tank for pressure testing in the following way:

- assemble items needed for testing, including compressor, soap/water solution, brush, sprayer, test manifold and pressure lines
- set the tank in an area where the tank can be safely manipulated and observed without risking property damage or injury
- install the test manifold(s)
- clean service fittings and plugs, and apply pipe thread sealant
- install gaskets, blinds and flange bolting
- seal service fittings, nozzles and other openings
- clean surfaces as required

4.9.2. PRESSURE TESTING A SINGLE-WALL TANK

4.9.2.1. See Pressure-Testing Sidebar for instructions.

4.9.3. TESTING A WET DOUBLE-WALL TANK

NOTICE

Never pressurize a wet interstitial space. Doing so could result in damage to the primary tank and/or tank failure.

4.9.3.1. See Pressure-Testing Sidebar for instructions.

4.9.4. TESTING A DRY-MONITOR, DOUBLE-WALL TANK WITH THE INTERSTITIAL SPACE UNDER VACUUM

NOTE: A dry-monitor, double-wall tank may be shipped from the factory with the interstitial space under vacuum. This option allows for monitoring the tank during shipping and handling, and may expedite tank installation by shortening preinstallation testing procedures. The date that the vacuum was applied is on a label near the monitor or on the shipping documentation delivered with the tank.

PRESSURE-TESTING SIDEBAR

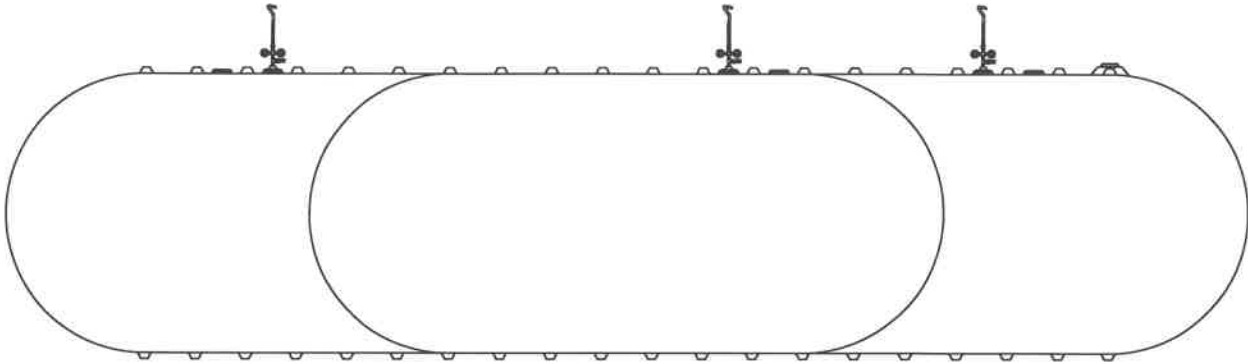

Single-Wall (or Primary) Tank

1. Pressurize the tank.
2. Check threaded or flanged joints for problems with the tank.
3. Soap the entire exterior of the tank (not applicable for a double-wall tank), including all service fittings and manways when present.
4. Hold and monitor the pressure for a minimum of 1 hour.
5. Carefully release the pressure from the tank.
6. Remove the test manifold and replace the protective covers in the service fittings.

Wet Double-Wall Tank

NOTICE

Never pressurize a wet interstitial space. Doing so could result in damage to the primary tank and/or tank failure.

1. Check the level of the monitoring fluid in the reservoir.
2. Visually check the interior and the exterior of each compartment for the presence of monitoring fluid.
3. If the monitoring fluid is not at the proper level, and/or monitoring fluid is found on either the interior or the exterior of any compartment, contact the manufacturing facility that shipped the tank.

4. If there is no monitoring fluid on either the interior or the exterior of any compartment, backfill the tank to the top of the tank.
5. After the tank is backfilled to the top of the tank, it may be pressure tested as in Single-Wall (or Primary) Tank steps 1-6.

NOTE: For multicompartment tanks, follow these instructions to test each compartment.

Dry Double-Wall Tank Not Under Vacuum

1. Test the primary tank as in Single-Wall (or Primary) Tank steps 1-4.
2. Use the quick-disconnect assembly to pressurize the interstitial space.
3. Soap the entire exterior of the tank.
4. Hold and monitor the pressure in the interstitial space for a minimum of 1 hour.
5. Carefully release the pressure from the primary tank.
6. Remove the test manifold and replace the protective covers in the service fittings.
7. After the tank is backfilled to the top of the tank, it may be pressure tested as in Single-Wall (or Primary) Tank steps 1-6.

Dry Double-Wall Multicompartment Tank Not Under Vacuum

1. Install a test manifold in the base tank and in each end compartment.
2. Pressurize the base tank and the end compartment(s) as in a Single-Wall (or Primary) Tank steps 1-4.
3. Pressurize the interstitial space using the quick-disconnect assembly and follow instructions for Dry Double-Wall Tank Not Under Vacuum steps 3-6.
4. After the tank is backfilled to the top of the tank, it may be pressure tested as in Single-Wall (or Primary) Tank steps 1-6.

Dry Double-Wall Tank Under Vacuum

1. Follow the pass/fail criteria shown in **section 4.9.4** for double-wall tank shipped under vacuum to determine if preinstallation pressure testing is required.
2. After the tank is backfilled to the top of the tank, it may be pressure tested as in Single-Wall (or Primary) Tank steps 1-6.

NOTE: All UL- and ULC-label and potable water tanks must be pressure tested after backfill is brought close to the top of the tank.

4.9.4.1. This date that the vacuum was applied may be used as a reference under this procedure to evaluate the tank's integrity prior to installation.

4.9.4.2. Tanks shipped under vacuum must be under vacuum for a minimum of 7 days. If this requirement is not met, a pressure soap test is required.

4.9.4.3. The tank shipped under vacuum should be installed and backfilled with the vacuum intact if both of the following two conditions are met:

- installation of the tank is to begin 7 days or more after the factory application of vacuum (as indicated on the shipping documents and/or tank labels)
- the vacuum gauge shipped with the tank reads 12 inches of mercury [40 kPa] or more

NOTE: Under certain field conditions (such as major changes in temperature, barometric pressure and/or altitude) and/or with certain equipment failure (such as freezing or sticking of gauge mechanism), the vacuum-monitoring method may not be an accurate enough test.

4.9.4.4. When in doubt, or when such conditions occur, see **Pressure-Testing Sidebar** for instructions on testing a dry, double-wall tank not under vacuum.

4.9.5. PRESSURE TESTING A DRY-MONITOR, DOUBLE-WALL TANK NOT UNDER VACUUM

4.9.5.1. See **Pressure-Testing Sidebar** for instructions.

4.9.6. PRESSURE TESTING A DRY-MONITOR, DOUBLE-WALL MULTICOMPARTMENT TANK NOT UNDER VACUUM

NOTICE

Do not connect pressure source directly to the access fitting for interstitial-space monitoring. Pressurizing the interstitial space by itself could result in damage to the primary tank and/or tank failure.

4.9.6.1. See **Pressure-Testing Sidebar** for instructions.

5: INSTALLING TANKS

5.1. GENERAL

5.1.1. Take safety precautions throughout the entire installation process. See the **Introduction**.

5.1.2. Use only approved backfill material. See **section 1.2**.

5.1.3. Do not mix approved material together with sand or in-situ soil.

5.1.4. Do not use in-situ soil as primary backfill material.

5.1.5. Typically, all excavated in-situ soil must be replaced with primary backfill material.

5.2. DRY-HOLE INSTALLATION

5.2.1. Before beginning tank installation, take a tank diameter measurement. See **section 1** for instructions.

5.2.2. Record this measurement as Measurement #1 on the Tank Installation Checklist.

5.2.3. Locate the excavation site according to instructions in **section 1**.

5.2.4. Prepare the excavation according to instructions in **section 1** and the following points:

- When preparing the excavation, allow for an anchoring system (if used) and geotextile fabric (if used). See **section 1**.
- When preparing the excavation, allow for the appropriate depth of cover as specified in **section 1**.
- If two or more tanks are to be installed in the same excavation hole, follow instructions in **section 1**.
- If the tank has a bottom sump or fitting, prepare the excavation hole according to instructions in **section 1**.

5.2.5. If an anchor slab is needed, install it now. See **section 1**.

5.2.6. Where necessary, level the bottom of the excavation using primary backfill material, filling in any low areas. See **section 1** for backfill requirements.

5.2.7. Geotextile fabric, if used, must be placed to separate the primary backfill material from all other in-situ soil and/or secondary backfill material. See **section 1**.

5.2.8. If deadmen are used, see **section 1** for information on deadmen placement.

- If deadmen are used and they are to be placed so that they are in the bedding or below the bottom of the tank, place the deadmen before preparing the backfill bedding.

5.2.9. Prepare a 12-inch-thick [30-cm-thick] smooth, level bed of approved primary backfill material on the bottom of the excavation or on top of slab. See **section 1** for backfill requirements.

NOTICE

If anchor straps are used, bedding must be carefully leveled. Failure to follow this notice could result in straps being too short or too long, which could result in property damage.

NOTE: If the excavation has soft soil conditions or if there might be difficulties controlling water accumulation, it is acceptable to increase the bedding thickness as needed. Set the tank anchors once the bedding thickness has reached a level 12 inches [30 cm] below the tank bottom elevation.

5.2.10. See **section 2** regarding the use of lifting lugs to hoist the tank when unloading and installing it.

NOTICE

Do not set tanks directly onto a concrete slab, timbers, cradles or in-situ soil. Failure to follow this notice could result in damage to the tank.

5.2.11. Place the tank or tanks onto the bed:

- If deadmen are in place, center the tanks between them.
- Align the tanks with anchors for proper placement of anchor straps.
- As the tank is being placed, slope the tank according to site specifications.
- Sloping of tanks may affect accuracy of calibration charts.
- If a double-wall tank is sloped, the monitor should be at the low end in a tank with a dry interstitial space and at the high end in a tank with a wet interstitial space.

NOTE: We do not require that a tank be sloped. However, sloping the tank may be required by the tank owner's specifications.

5.2.12. Use the tops of the ribs to establish longitudinal level. Establish lateral level by placing the level across the top of a fitting or a manway.

NOTICE

Do not place straps between ribs (not applicable for 4-foot-diameter tanks). Failure to properly place straps could result in damage to the tank.

5.2.13. If anchor straps are to be used, install them at this time. See **section 1** and follow these instructions:

- The locations for anchor straps are marked on tank ribs by the arrow head symbol (on the tank itself on 4-foot-diameter tanks).
- All marked anchor strap locations must have straps.
- Place a strap on each marked location and install anchoring hardware. See **section 1**.
- Tighten each anchor strap until it is snug over the rib (over the tank itself on a 4-foot-diameter tank), but does not cause any deflection of the tank. Straps must be uniformly tight.
- A 12-inch-thick [30 cm] bedding is required under the tank, even when low-profile deadmen are used.
- After the straps have been installed and tightened, take a tank diameter measurement to check tank deflection, and record it as Measurement #2 on the Tank Installation Checklist.

NOTICE

Overdeflection of the tank could result in damage to the tank.

5.2.14. Install bottom fittings and bottom piping on water/wastewater tanks at this time. See **section 5.4**.

5.2.15. Place approximately 12 inches [30 cm] of primary backfill around the bottom of the tanks between the ribs (if present) and under the end domes.

- Use a nonmetal tamping rod long enough to reach beneath the tank to push material under the tank body and domes until solid resistance is felt. All voids must be filled and the tank must be fully supported. See **Figure 5-1**.

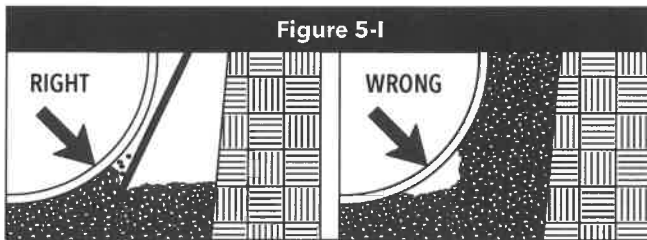

NOTICE

Do not use metal probes. Failure to follow this notice could result in damage to the tank.

NOTICE

Do not strike the tank with the tamping rod. Failure to heed this notice could result in damage to the tank.

5.2.16. Repeat **point 5.2.15** with a second lift of approximately 12 inches [30 cm] of primary backfill.

5.2.17. After the second lift of material has been placed and worked under the tank, bring the backfill to the top of the tank.

- Place backfill material evenly on opposite sides of the tank so that the tank does not shift.

5.2.18. If secondary backfill material is to be used on the perimeter of the installation, it must be placed and compacted at the same time as the primary backfill material.

5.2.19. During the backfilling process, it is good practice to continue to check tank deflection.

NOTICE

Thoroughly hand-tamp backfill to eliminate all voids under the tank. Do not allow the tank to shift during the backfill procedure. If there are voids under the tank and/or the tank has shifted once backfilling has commenced, it will be necessary to remove and reinstall the tank. Failure to follow this notice could result in damage to the tank and other property damage.

5.2.20. After backfill has been brought to the top of the tank, take another tank diameter measurement. Record it as Measurement #3 in the Tank Installation Checklist, and determine whether tank deflection is within the allowable limits.

5.2.21. All UL-label, ULC-label and potable water tanks must be pressure tested after backfill is brought close to the top of the tank.

5.2.22. If additional testing (postinstallation testing for pressure-testable tanks or optional hydrostatic testing) is to be done, perform those tests now. See **section 6** for instructions.

5.2.23. Typically, installers choose whether the tank should be ballasted at this time. See **section 5.5** for instructions.

5.2.24. If piping and/or venting needs to be installed, complete this work now. See **section 7** for instructions.

5.2.25. If containment sumps need to be installed, do that now. See **section 7** for instructions.

5.2.26. Continue to backfill to grade, or to subgrade if concrete or asphalt is to be installed.

5.2.27. When the tank has been backfilled to subgrade (but before placement of slab), take the last required tank diameter measurement.

- Record it as Measurement #4 and determine whether tank deflection is within the allowable limits shown in **Table 1-6**.
- Subtract Measurement #4 from Measurement #1 and record it as the Deflection Measurement on the Tank Installation Checklist.

5.2.28. Install reinforced or unreinforced concrete/asphalt, if used, at this time. See **section 1**.

- The cover depth must meet the appropriate minimum specified in **section 1**.
- All backfill that is to be compacted must be compacted with a hand-guided, vibrating-plate, mechanical compactor.

NOTICE

Do not use rammer-type compactors over the top of the tank. Failure to follow this notice could result in damage to the tank and/or surrounding property.

5.2.29. If the tank has a monitoring system, after backfilling is completed and after top slab is in place (if used), perform necessary monitoring checks. See **section 8**.

5.2.30. Complete the Tank Installation Checklist.

5.3. WET-HOLE INSTALLATION

5.3.1. Follow the dry-hole installation instructions (in **section 5.2**) with the modifications listed.

5.3.2. Perform **points 5.2.1 through 5.2.4** of the dry-hole installation instructions.

5.3.3. Before performing **point 5.2.5** of the dry-hole installation instructions, pump water from the excavation hole and continue pumping to maintain minimum water level during tank installation.

- Attempt to maintain the water level below the top of the bedding materials until the tank can be fully backfilled and ballasted.

5.3.4. Proceed with **points 5.2.5 through 5.2.9** of the dry-hole installation instructions.

5.3.5. Proceed with **points 5.2.10 through 5.2.12** of the dry-hole installation instructions.

5.3.6. In high-water conditions, where it is not possible to maintain the water level below the top of the bedding material during the entire installation, partially ballast the tank to firmly seat the tank into the bedding material and to keep it from floating. See **section 5.5** for instructions.

5.3.7. The ballast level in the tank must either be lower than the backfill material or less than 12 inches [30 cm] above the water level in the hole. See **Figure 5-2**.

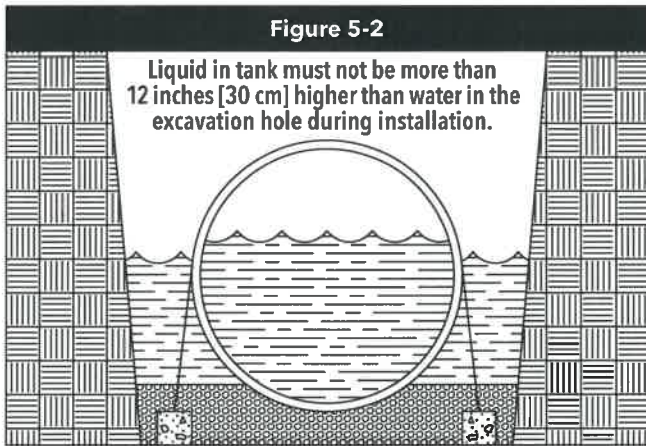

5.3.8. Proceed with **points 5.2.13 through 5.2.23** of the dry-hole installation instructions.

5.3.9. Ballast the tank once the backfill is even with the top of the tank. See **section 5.5**.

5.3.10. Proceed with **points 5.2.25 through 5.2.30** of the dry-hole installation instructions.

5.4. BOTTOM SUMPS AND FITTINGS

5.4.1. GENERAL

5.4.1.1. When handling a tank with a bottom sump or fitting, always take extra care so that the bottom sump or fitting is not damaged by contact with any other object, such as the truck bed or the ground.

NOTE: During transportation and at the jobsite, tanks with bottom sumps must be cradled to avoid damage caused by allowing the tank to rest on the sump.

5.4.1.2. When installing a large bottom sump in a water or wastewater tank, see the Large Bottom Sump Installation Instructions supplement. See the **Introduction** for details on where to obtain this supplement.

NOTICE

All connections to the tank must be flexible. Provisions must be made to accommodate movement and misalignment between the piping and the tank. Failure to do this could result in damage to the tank and/or surrounding property.

5.4.1.3. While preparing the backfill bedding, dig a hole in the bottom of the excavation that is large enough to accommodate the bottom sump or fitting.

5.4.1.4. When installing a UL- or ULC-label tank equipped with a bottom sump, excavation and bedding must be modified to provide a 12-inch-deep [30-cm-deep] by 24-inch-diameter [61-cm-diameter] hole centered at the sump location.

5.4.1.5. The required 12 inches [30 cm] of backfill bedding on the bottom of the excavation must also be present in the excavation hole in which the bottom sump or fitting will be placed.

5.4.1.6. After the tank is placed, manually tamp backfill in the void surrounding the sump prior to adding backfill around the tank.

5.5. BALLASTING TANKS (ADDING LIQUID)

⚠ WARNING

Inert the tank and use inert gases (not air) to pressure test a tank that contains or has contained flammable or combustible liquids or vapors. Failure to follow this warning could result in an explosion, and could result in death or serious injury.

⚠ WARNING

If flammable or combustible product is used as ballast, exercise special care in handling. Safeguard against sparks, fire or product spills. Failure to follow this warning could result in a fire or an explosion, and could result in death or serious injury.

⚠ WARNING

The tank must be adequately vented to prevent the development of vacuum or pressure when filling or emptying the tank. Failure to properly vent the tank could cause tank failure, and could result in death or serious injury.

5.5.1. GENERAL

5.5.1.1. Typically, tanks should be pressure tested before ballasting.

- Do not use atmospheric air when testing pressure-testable tanks that have held flammable or combustible product.
- Use nitrogen or other inert gas when testing these tanks.

5.5.1.2. For most anchoring systems, a tank is not adequately protected against flotation until the tank is fully backfilled and the top slab is in place. Therefore, during the installation process, the tank should be ballasted completely after the backfill is at least 75 percent of the way up the tank and after postinstallation testing has been successfully completed.

5.5.1.3. Only under wet-hole conditions should ballast be added before the backfill is 75 percent of the way up the tank. See **section 5.3**.

5.5.1.4. Care must be taken so that the use of ballast does not contaminate the product being stored. This is especially important for potable water, chemical and diesel exhaust fluid (DEF) tanks.

5.5.1.5. Contamination can be avoided by doing one of the following:

- ballast the tank with a liquid compatible with the product being stored OR
- clean the tank after ballasting to eliminate any contaminating product

⚠ WARNING

Inert the tank and use inert gases (not air) to pressure test a tank that contains or has contained flammable or combustible liquids or vapors. Failure to follow this warning could result in an explosion, and could result in death or serious injury.

⚠ WARNING

If flammable or combustible product is used as ballast, exercise special care in handling. Safeguard against sparks, fire or product spills. Failure to follow this warning could result in a fire or an explosion, and could result in death or serious injury.

6: POSTINSTALLATION TESTING

6.1. PRESSURE TESTING TANKS

6.1.1. If the tank is a water/wastewater tank equipped for pressure testing, follow the procedures in the Preinstallation Testing Instructions for Water/Wastewater Tanks Factory-Equipped for Pressure Testing supplement. See the **Introduction** for information on how to obtain this supplement.

6.1.2. All UL-label, ULC-label and potable water tanks must be pressure tested after backfill is brought close to the top of the tank.

6.1.3. If the tank is ballasted with water, the tank can be pressurized for pressure testing. See **Pressure-Testing Sidebar**.

6.2. OPTIONAL HYDROSTATIC TESTING

6.2.1. This optional test is typically used for water or wastewater tanks that are not pressure-testable due to the accessories on the tank.

6.2.2. Use the following procedure for this test:

- Seal off the influent and effluent piping, and any fittings that are below the tank top with watertight caps or plugs.
- Fill the tank with water to a level that is 3 inches [7.6 cm] into the access openings after the backfill is at least 75 percent of the way up the tank.
- Let the water stand in the tank for a minimum of 1 hour (or longer if required by applicable local codes).
- Allow sufficient time so that the water temperature stabilizes.
- If the water level drops, check to see that plugs or caps sealing off the piping are tight. Then add more water to fill air voids and return the water level back to the standard testing level.
- If the water level does not stabilize, contact the manufacturing facility that shipped the tank.

7: PIPING, VENTING AND CONTAINMENT SUMPS

7.1. INTERNAL PIPING

7.1.1. All piping must conform to all applicable codes and standards.

NOTICE

All internal piping must be at least 4 inches [10 cm] from the tank bottom. Failure to follow this notice could result in damage to the tank and/or surrounding property.

NOTICE

All metal fittings and other metal components must be coated to protect against corrosion. Failure to do this could result in damage to these parts, the tank and/or surrounding property.

7.1.2. For tanks equipped with manways, see table and relevant figure in **Piping Sidebar** to determine the correct length for internal piping.

7.1.3. For tanks equipped with access openings, see table and relevant figure in **Piping Sidebar** to determine the correct length for internal piping.

7.2. EXTERNAL PIPING

⚠ WARNING

The tank must be isolated from all piping when the external piping is being pressure tested. The test pressures for external piping could cause tank failure, and could result in death or serious injury.

7.2.1. When extending monitoring or vapor-recovery piping to the surface, make sure the at-grade fittings are different from any fill fittings and will not accept standard fill hoses.

NOTICE

All connections to the tank must be flexible. Provisions must be made to accommodate movement and misalignment between the piping and the tank. Failure to do this could result in damage to the tank and/or surrounding property.

7.3. VENTING TANKS

⚠ WARNING

All underground tanks/compartments shall be adequately vented to prevent the development of vacuum or pressure when filling or emptying the tank. Failure to properly vent a tank or compartment could cause tank failure, and could result in death or serious injury.

7.3.1. The primary tank is designed to operate at atmospheric pressure.

7.3.2. The tank's venting system must be adequately sized to ensure that atmospheric pressure is maintained at all times, including during filling and emptying of tank.

7.3.3. Whenever installing overflow protection, such as an alarm, an automatic shut-off device (fill pipe flapper valve) or a vent-restriction device (ball-float valve), follow the instructions provided by the manufacturer of the overflow-protection device and consult the authority having jurisdiction to determine the level at which the overflow protection should operate.

- Some jurisdictions do not allow ball-float valves.
- Consult applicable codes and regulations.

⚠ WARNING

Vent-restriction devices for overflow should not be installed if owner/operator will allow pump- or pressure-filling of tank. Failure to follow this warning could cause tank failure, and could result in death or serious injury.

PIPING SIDEBAR

TANKS WITH MANWAYS

Single-Wall & Double-Wall

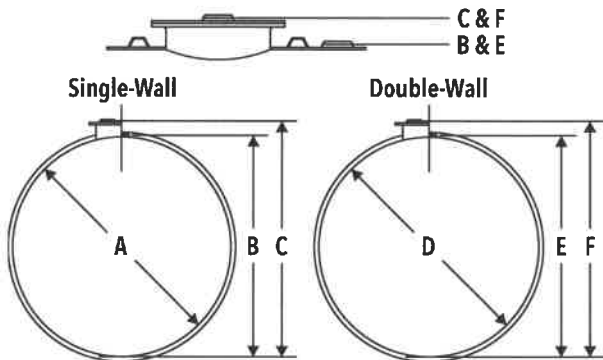

- A. Internal diameter of a single-wall tank with a manway.
- B. Dimension from the top of a service fitting to the inside bottom of a single-wall tank.
- C. Dimension from the top of a service fitting on a manway cover to the inside bottom of a single-wall tank.
- D. Internal diameter of a double-wall tank.
- E. Dimension from the top of a service fitting to the inside bottom of a double-wall tank.
- F. Dimension from the top of a service fitting on a manway cover to the inside bottom of a double-wall tank.

- NOTE:**
1. All fitting dimensions are measured from the top of a service fitting to the inside bottom of the tank and include striker plate clearance if applicable.
 2. Interior diameters do not include striker plate clearance.
 3. Nominal dimensions shown. Actual dimensions are plus or minus 1/2" [1.3 cm].

TANKS WITH ACCESS OPENINGS

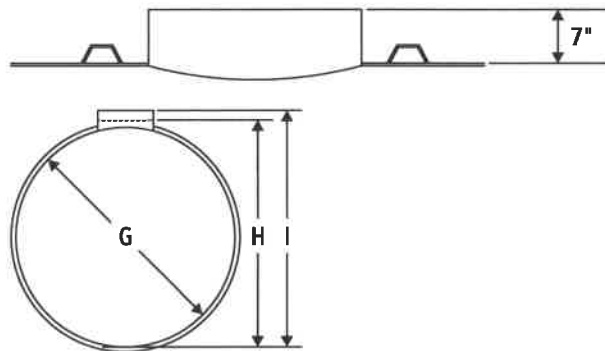

- G. Internal diameter of a single-wall tank with an access opening.
- H. Dimension from the inside bottom of single-wall tank and an internal flange on an access opening.
- I. Dimension from the inside bottom of a single-wall tank and the top of an access opening.

Table 7-1

Tank Diameter	A	B	C	D	E	F	G	H	I
4-foot (Red Tank)	48" [122 cm]	49 1/2" [126 cm]	54 1/2" [138 cm]	48" [122 cm]	49 1/2" [126 cm]	54 1/2" [138 cm]	48" [122 cm]	51 1/4" [130 cm]	55 1/4" [140 cm]
4-foot (Green Tank)	48 3/4" [124 cm]	49 1/4" [125 cm]	55 3/4" [142 cm]	48 3/4" [124 cm]	49 1/2" [126 cm]	56" [142 cm]	48 3/4" [124 cm]	51 3/4" [131 cm]	55 3/4" [142 cm]
6-foot (Red Tank)	71 3/8" [181 cm]	73" [185 cm]	78" [198 cm]	70 3/4" [180 cm]	72 1/2" [184 cm]	77 3/4" [197 cm]	71 3/8" [181 cm]	74 3/4" [190 cm]	78 3/4" [200 cm]
6-foot (Green Tank)	71 1/2" [182 cm]	73" [185 cm]	79 1/2" [202 cm]	71" [180 cm]	72 3/4" [185 cm]	79 1/4" [201 cm]	71 1/2" [182 cm]	74 3/4" [190 cm]	78 3/4" [200 cm]
8-foot (Red Tank)	91 1/4" [232 cm]	93" [236 cm]	98" [249 cm]	90" [229 cm]	91 3/4" [233 cm]	97" [246 cm]	91 1/4" [232 cm]	94 1/2" [240 cm]	98 1/2" [250 cm]
8-foot (Green Tank)	97 1/2" [248 cm]	99" [251 cm]	105 1/2" [268 cm]	97" [246 cm]	98 3/4" [251 cm]	105 1/4" [267 cm]	97 1/2" [248 cm]	100 3/4" [256 cm]	104 3/4" [266 cm]
10-foot (Red Tank)	119 1/4" [303 cm]	121" [307 cm]	126" [320 cm]	118" [300 cm]	119 3/4" [304 cm]	125" [318 cm]	119 1/4" [303 cm]	122 1/2" [311 cm]	126 1/2" [321 cm]
10-foot (Green Tank)	120 1/4" [305 cm]	121 3/4" [309 cm]	128 1/4" [326 cm]	119 7/8" [304 cm]	121 7/8" [310 cm]	128 1/8" [325 cm]	120 1/4" [305 cm]	123 1/2" [314 cm]	127 1/2" [324 cm]
12-foot	136 5/8" [347 cm]	138 1/4" [351 cm]	143 1/4" [364 cm]	135 7/8" [345 cm]	137 7/8" [350 cm]	142 7/8" [363 cm]	136 5/8" [347 cm]	140" [356 cm]	144" [366 cm]

7.4. VENTING INTERSTITIAL SPACES

NOTICE

All wet monitoring systems must be vented for proper operation. Failure to do this could result in damage to the tank and/or surrounding property.

7.4.1. When the tank's interstitial space is filled with a monitoring fluid, the space must be vented. It is sufficient to drill a 1/4-inch-diameter [6-mm-diameter] hole in the side or cap of the reservoir standpipe as supplied by the installer. If the groundwater level could be high enough to enter a drilled vent hole, install a vent line from the standpipe and position it above the high-water level.

7.4.2. When the interstitial space is dry, it is not necessary to vent the space to atmosphere.

7.5. INSTALLING CONTAINMENT SUMPS

7.5.1. Containment sumps come in a variety of models and sizes.

7.5.2. Instructions for the different models are found in supplemental materials. See the **Introduction** for information on where to obtain supplemental instructions.

7.5.3. The containment sump provides an enclosure for a submersible pump and a termination point for secondary piping systems.

- It provides containment of product from the pump and/or piping connections.
- It is designed to be monitored continuously using electronic sensors.

7.5.4. Before installing containment sumps:

- consult all codes and regulations of appropriate governmental agencies to ensure proper monitoring compliance
- ensure that all containment sumps will be isolated from traffic loads
- perform a visual inspection of the sump for potential shipping damage
- contact the manufacturing facility that shipped the tank if damage is detected
- check to make sure the sump is the correct length for intended burial depth.
- obtain the specific containment sump supplement for the application installation. See **Introduction** for list of supplements.

7.5.5. Install the containment sump according to the supplemental instructions that apply. Go to zcl.com to find additional copies of the supplements.

CAUTION

Always wear eye protection and gloves when handling, grinding, cutting and attaching the containment sump unit. Failure to do so could result in minor or moderate injury.

NOTICE

Do not drop the containment sump assembly components or allow the sump body to roll. Since high winds could damage the sump components, protect and secure all pieces if windy conditions arise. Failure to follow this notice could result in damage to surrounding property.

NOTICE

Make sure that no heavy objects are allowed to distort the containment sump top after final assembly. This includes the street box and concrete pad. No weight should be transferred to the tank. Failure to follow this notice could result in property damage.

7.5.6. To complete the containment sump installation:

- Backfill to the top of the containment sump system.
- Backfill around the outside edge of the containment sump, making sure that no backfill is on top of the containment sump. See **Figure 7-1, Backfill A**.
- Isolate the containment sump from all traffic loads.
- Install a concrete form/barrier (for example, the concrete pad/street-box frame) to allow a minimum 3-inch [7.5 cm] clearance between any load-bearing item and the containment sump top.
- Typically, a sheet of plywood (or other material) is used as a barrier and is set on the backfill to ensure that there is at least a 3-inch [7.5 cm] clearance above the containment sump top. See **Figure 7-1, Barrier B**.
- Choose a street-box size that allows enough clearance around the containment sump top opening for proper operation of the cover.
- Set the street box, and check for clearance to allow access and space to remove the watertight cover. See **Figure 7-1, Street Box C**.
- Continue with backfill, as required, to subgrade. See **Figure 7-1, Backfill A**.
- Maintain good drainage of water away from the access opening of the containment sump top when installing the surface pad. See **Figure 7-1, Surface Pad D**.

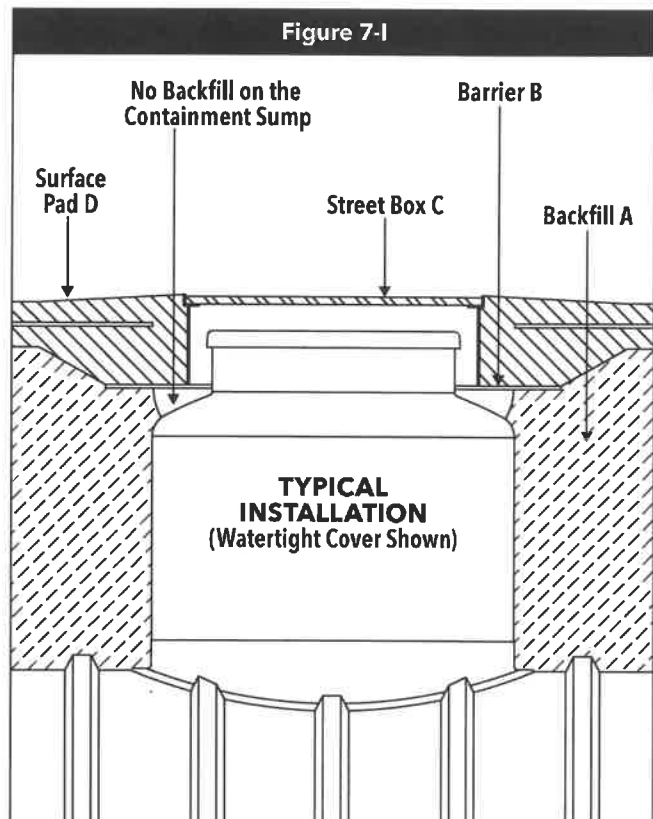

8: COMPLETING INSTALLATION

8.1. TAKING DIAMETER MEASURE #4.

8.1.1. When the tank has been backfilled to subgrade (but before placement of concrete or asphalt), take the last required tank diameter measurement. Record it as Measurement #4 on the Tank Installation Checklist and determine whether tank deflection is within the allowable limits shown in the Installation Manual.

8.1.2. In a tank with a wet interstitial space, the level of the monitoring fluid may have changed during backfill. Therefore, the level of the monitoring fluid must be checked and/or adjusted for proper level after backfill and top slab placement is completed.

8.2. MONITORING TANKS

8.2.1. It is the responsibility of the tank owner and/or operator to determine the appropriate monitoring system and method if one is to be used.

8.3. MONITORING SINGLE-WALL TANKS

8.3.1. Single-wall tank installations may require release detection monitoring, which can include inventory control, automatic tank gauging, vapor monitoring or groundwater monitoring.

8.3.2. Check with appropriate governmental agency officials for requirements in your area.

8.4. MONITORING DOUBLE-WALL TANKS

8.4.1. A double-wall tank has an interstitial space between the wall of the primary (internal) tank and the wall of the secondary (external) tank for the detection and containment of product from the primary tank.

8.4.2. A double-wall tank, as supplied, will have a minimum of 1 monitoring access fitting that provides access into the interstitial space.

8.4.3. Liquid and vapor sensors are installed through the monitoring access fitting.

- Most sensors can be installed after the tank has been backfilled to grade.
- For ease of installation, the sensor may be inserted into the monitoring access fitting before installing the monitoring riser pipe to grade.

8.5. MONITORING DOUBLE-WALL TANK WITH A DRY INTERSTITIAL SPACE

8.5.1. A safe electronic or mechanical monitoring system should be used to detect product and incoming water.

8.5.2. The monitoring system should detect product and water at the bottom of the interstice.

- Use a drawstring to position the monitoring sensor at or near the bottom of the tank.
- If a double-wall tank is sloped, the monitor should be at the low end.

8.5.3. For liquid or vapor sensors, the monitoring access fitting may be vented to atmosphere (independent from the primary tank) or sealed.

8.6. MONITORING DOUBLE-WALL TANK WITH A WET INTERSTITIAL SPACE

8.6.1. A double-wall tank may be shipped with a factory-installed TRUCHEK® monitoring system, which enables the owner to have continuous monitoring or to conduct a tank-tightness test.

- TRUCHEK meets the EPA criteria for tank-tightness testing. See the TRUCHEK brochure for more information.
- When a double-wall tank is shipped with the TRUCHEK monitoring system, the interstitial space is typically filled with monitoring fluid at the manufacturing facility.
- Some tanks with TRUCHEK installed may be shipped with extra monitoring fluid so the monitoring-fluid level can be topped off.
- Do not add monitoring fluid until after tank burial is completed and the monitoring system is set up.

NOTICE

All wet interstitial spaces must be vented to atmosphere. Failure to follow this notice could result in damage to the tank and/or surrounding property. See section 7.3.

NOTICE

Monitoring fluid should not be present in the standpipe except during a TRUCHEK test. Monitoring fluid in the standpipe could create excessive pressure on the interstitial space and could result in damage to the tank. See the TRUCHEK brochure for more information.

8.6.2. When the tank is delivered and before it is installed, check the monitoring-fluid level and record it on the shipping/receiving paperwork and Tank Installation Checklist.

- The required operating level for the monitoring fluid in the reservoir is 1/2 full. If necessary, add monitoring fluid to meet that level—BUT not until after the tank is buried and the monitoring system is set up.
- If monitoring fluid is not in the reservoir, contact the manufacturing facility that shipped the tank.
- In a tank with the interstice filled with monitoring fluid, using a nonmetallic standpipe in the reservoir is recommended.
- The monitoring-fluid level may fluctuate during shipping and installation.
- If a tank is sloped, the reservoir should be at the high end.

8.6.3. During the installation process, the monitoring-fluid level in the reservoir will rise naturally under various conditions:

- preinstallation pressure test
- rise in groundwater level
- backfill compaction
- ballasting
- temperature increase

8.6.4. Check and record the monitoring-fluid level during the installation process. See the Tank Installation Checklist.

8.7. SETTING THE LEVEL OF THE MONITORING FLUID

8.7.1. After completing the backfilling and placing the top slab:

- check the level of the monitoring fluid in the reservoir and set the monitoring fluid to the proper level.
- Failure to set the monitoring-fluid level properly could lead to false alarms.

8.7.2. Once the tank is installed, the level of the monitoring fluid may fluctuate due to such things as:

- product level
- groundwater fluctuation
- tank filling and emptying
- product-temperature variation

8.7.3. To establish the proper operating level for monitoring fluid, decide what type of monitoring probe will be used in order to determine the initial starting point for the level in the reservoir.

8.7.4. Observe the following instructions when using a probe:

- Do not raise it off the tank to meet the monitoring-fluid level.
- Keep the probe upright and in contact with the top of the tank at all times. See **Figure 8-1**.
- When using a two-sensor probe (typical probe with a high-fluid level and a low-fluid level), the starting point (the proper level for the monitoring fluid) is midway between the two sensors.
- If using something other than a two-sensor probe, use 7 inches [18 cm] from the top of the tank as the starting point for the monitoring-fluid level.
- After determining the starting point, adjust the monitoring fluid based on the product level.
- If the tank is between $\frac{1}{4}$ and $\frac{1}{2}$ full of product, the proper operating level for the monitoring fluid is at the starting point.
- If the tank is between empty and $\frac{1}{4}$ full, the proper operating level for the monitoring fluid is about 1 inch [3 cm] below the starting point.
- If the tank is between $\frac{3}{4}$ full and full, the proper operating level for the monitoring fluid is about 1 inch [3 cm] above the starting point.
- Add or remove monitoring fluid to reach the proper operating level for the monitoring fluid.

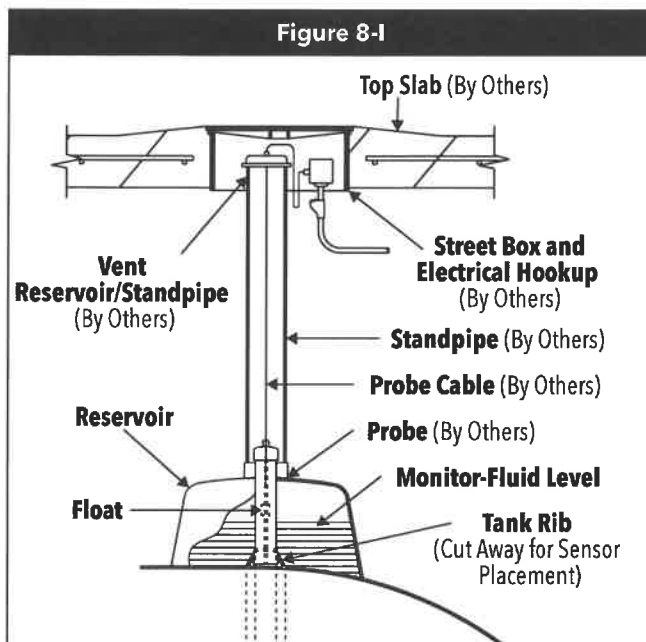

8.7.5. If a TRUCHEK test is required after installation, follow the procedures in the TRUCHEK brochure.

- After this test, reset the monitoring-fluid level to a position based on the product level.

9: OPERATING GUIDELINES

9.1. GENERAL

9.1.1. Owner must retain the Installation Manual and Operating Guidelines for future reference to operating guidelines.

9.1.2. In addition to this Installation Manual, follow all laws, regulations, codes and safety precautions of appropriate governmental agencies that pertain to underground storage tanks and/or their associated systems.

9.1.3. Consult supplemental materials (see the **Introduction**), tank brochures, separate product instructions (such as oil/water separators) and separate accessory instructions, which are available upon request from the manufacturing facility that shipped the tank. Most of these documents are also available at zcl.com and through technical support.

9.1.4. Consult the applicable limited warranty for further operating guidelines and limitations. A copy of our current limited warranty is found at zcl.com. The tank owner should retain the limited warranty.

9.2. TEMPERATURE LIMITS FOR STORED PRODUCTS AND MATERIALS

9.2.1. Each tank is designed to store products and materials identified in the manufacturer's applicable limited warranty.

NOTICE

Products and materials must be stored in the tank appropriate for the specific product or material. Failure to follow this notice could result in damage to the tank and/or surrounding property.

NOTICE

Storing products and materials other than those identified in the manufacturer's applicable limited warranty will void the tank manufacturer's obligations under the limited warranty and could result in tank failure and/or damage to surrounding property.

9.2.2. The temperature of stored products and materials must not exceed the temperature specified in the manufacturer's applicable limited warranty.

NOTICE

Introducing or storing a product or material into a tank in excess of the allowable temperature could damage the tank. Failure to follow this notice could result in damage to the tank and/or surrounding property.

NOTICE

Care should be taken not to allow accumulation of water inside the containment sumps, as it can freeze during winter conditions and result in damage to tank and property.

9.3. ENTERING TANKS

9.3.1. Do not allow anyone to enter the tank unless it has been properly emptied and vented, and unless the person entering the tank has been trained in confined-space entry procedures and applicable OSHA regulations or appropriate Canadian federal and provincial regulations.

▲ WARNING

Improper tank entry could cause fire, explosion or asphyxiation, and could result in death or serious injury.

9.4. FILLING TANKS (IN GENERAL)

9.4.1. Never overfill the tank.

9.4.2. If pump-filling or pressure-filling a tank, owner/operator must take precautions to prevent overpressurization.

▲ WARNING

Overpressurizing the tank could result in tank failure, and could result in death or serious injury.

▲ WARNING

If a tank does not have overfill protection, the vent must be unrestricted and the vent size must be equal to or greater than the fill. Failure to follow this warning could result in death or serious injury.

9.5. FILLING UL-LABELED/ULC-LABELED TANKS

▲ WARNING

Pump-filling or pressure-filling of the tank is not recommended because an overfill or overpressurization could occur. Overfilling the tank while under pressure could cause tank failure even if the tank is vented properly. Failure to follow this warning could result in tank failure, and could result in death or serious injury.

9.5.1. Each time the tank is filled, the tank owner or operator must make sure the tank is properly vented. See **section 7**.

9.5.2. The tank owner or operator must determine whether the tank has overfill protection, such as an automatic shut-off device (fill pipe flapper valve) or vent-restriction device (ball-float valve), which will close off the internal piping and reduce the tank's capacity.

- If a tank has a vent-restriction device (ball-float valve), we recommend that the tank be gravity-filled only.
- The tank owner or operator must notify whoever fills the tank if the tank has overfill protection, which reduces the tank's capacity.
- Before each tank filling, the tank owner or operator or the delivery service must determine the tank's reduced capacity due to the overfill protection.
- Then, the tank owner or operator or the delivery service must consult the instructions or guidelines provided by the installer and manufacturer of the overfill-protection device to determine how much additional product the tank can hold.

9.5.3. The tank owner or operator must ensure that the fill line and drop tube are adequately grounded to prevent static discharge during filling.

9.5.4. Initial fill rate should be controlled to limit the possibility of product sloshing.

10.1.2. After installation, tank owner must retain:

- the Installation Manual for future reference to and compliance with operating guidelines,
- the Tank Installation Checklist
- the limited warranty
- any written waivers applicable to these instructions.

10.2. APPENDICES

10.2.1. These appendices are found in the following pages:

- **Appendices A1, A2, A3, A4:** Actual Capacities and Dimensions of Single-Wall and Double-Wall Tanks
- **Appendices B1, B2, B3, B4:** Weights of Single-Wall, Double-Wall and Multicompartment Tanks
- **Appendix C:** Primary Backfill Requirements
- **Appendix D:** Split Backfill Requirements
- **Appendix E:** Tank Installation Checklist

10: DOCUMENT REVIEW

10.1. INSTALLATION MANUAL

10.1.1. After installation, tank installer must deliver the following to the tank owner and keep a copy of each:

- the Installation Manual
- completed Tank Installation Checklist

APPENDIX AI

Actual Capacities and Dimensions of Single-Wall and Double-Wall Tanks Manufactured and Installed in the United States (Red Tanks)

Refer to the Introduction of the Installation Manual for guidelines on the use of this chart.

	Nominal Capacity (gallons)	Actual Capacity (gallons)		Actual Tank Diameter (feet/inches)	Actual Tank Length (feet/inches)	Anchor Straps (# if required)
	SW & DW	SW	DW	SW & DW	SW & DW	
4 ft	600	602	602	4' ½" SW 4' 1" DW	6' 11 ⅞" SW 7' 3 ½" DW	2 2
	700	694	694	4' ½" SW 4' 1" DW	8' 0" SW 8' 3 ⅞" DW	2 2
	1,000	1,009	1,009	4' 3 ½" SW 4' 4" DW	11' 3 ⅞" SW 11' 7 ½" DW	2 2
	1,500	1,449	1,449	4' 3 ½" SW 4' 4" DW	16' 0" SW 16' 3 ⅞" DW	2 2
	2,000	2,013	2,013	4' 3 ½" SW 4' 4" DW	22' 0" SW 22' 3 ⅞" DW	2 2
6 ft	2,000	2,376	-	6' 3 ½"	13' 5 ¾" SW	2
	2,500	-	2,324	6' 3 ½"	13' 5 ¾" DW	2
	3,000	2,973	2,910	6' 3 ½"	16' 4 ¼"	2
	4,000	4,131	3,789	6' 3 ½"	21' 11 ⅞" SW 20' 8" DW	2 2
	5,000	5,064	4,961	6' 3 ½"	26' 5"	4
	6,000	5,960	5,840	6' 3 ½"	30' 8 ¾"	4
	7,000	7,154	-	6' 3 ½"	36' 5 ¾" SW	4
	8,000	8,050	-	6' 3 ½"	40' 9 ½" SW	4
8 ft	2,000	2,189	-	8' 0"	9' ½" SW	2
	3,000	3,271	3,249	8' 0"	12' 3"	2
	4,000	4,218	4,190	8' 0"	15' ½"	2
	5,000	5,165	5,089	8' 0"	17' 8 ½"	2
	6,000	6,084	6,044	8' 0"	20' 6 ½"	2
	7,000	6,946	6,900	8' 0"	23' 1"	2
	8,000	7,950	7,899	8' 0"	26' ½"	4
	9,000	8,869	8,812	8' 0"	28' 9"	4
	10,000	9,816	9,753	8' 0"	31' 6 ½"	4
	11,000	10,763	10,694	8' 0"	34' 4"	4
	12,000	11,682	11,608	8' 0"	37' ½"	4

Table Continued on Next Page →

	Nominal Capacity (gallons)	Actual Capacity (gallons)		Actual Tank Diameter (feet/inches)	Actual Tank Length (feet/inches)	Anchor Straps (# if required)
	SW & DW	SW	DW	SW & DW	SW & DW	
8 ft	13,000	13,081	13,000	8'0"	41'2"	6
	14,000	14,028	13,941	8'0"	43'11½"	6
	15,000	14,975	14,881	8'0"	46'9"	6
10 ft	7,000	7,358	7,258	10'4"	15'11¼"	4
	8,000	8,160	8,050	10'4"	17'3¾"	4
	9,000	8,961	8,841	10'4"	18'8¼"	4
	10,000	10,563	10,420	10'4"	21'5¼"	4
	11,000	11,364	11,210	10'4"	22'9¾"	4
	12,000	12,068	11,904	10'4"	24'¼"	4
	13,000	12,966	12,790	10'4"	25'6¾"	4
	14,000	13,767	13,580	10'4"	26'11¼"	4
	15,000	15,248	15,041	10'4"	29'5¾"	4
	16,000	16,851	16,621	10'4"	32'2¾"	6
	17,000	17,652	17,412	10'4"	33'7¼"	6
	18,000	18,453	18,202	10'4"	34'11¾"	6
	19,000	19,254	18,992	10'4"	36'4¼"	6
	20,000	20,055	19,782	10'4"	37'8¾"	6
	21,000	21,779	21,481	10'4"	40'8¼"	8
	22,000	22,580	22,271	10'4"	42'¾"	8
	23,000	23,381	23,061	10'4"	43'5¼"	8
	24,000	24,181	23,851	10'4"	44'9¾"	8
	25,000	25,783	25,431	10'4"	47'6¾"	8
	26,000	26,540	26,222	10'4"	48'11¼"	8
	27,000	27,385	27,012	10'4"	50'3¾"	8
	28,000	28,141	27,802	10'4"	51'8¼"	8
	29,000	29,741	29,382	10'4"	54'¾"	8
30,000	30,590	30,172	10'4"	55'9¾"	10	
31,000	32,142	31,752	10'4"	58'6¾"	10	
32,000	32,942	32,542	10'4"	59'11¼"	10	
33,000	33,794	33,332	10'4"	61'3¾"	10	
34,000	34,543	34,122	10'4"	62'8¼"	10	
35,000	35,397	34,912	10'4"	64'¾"	12	

Continued on Next Page →

	Nominal Capacity (gallons)	Actual Capacity (gallons)		Actual Tank Diameter (feet/inches)	Actual Tank Length (feet/inches)	Anchor Straps (# if required)
	SW & DW	SW	DW	SW & DW	SW & DW	
10 ft	36,000	36,944	36,492	10' 4"	66' 9¾"	12
	37,000	37,744	37,283	10' 4"	68' 2¼"	12
	38,000	38,544	38,073	10' 4"	69' 6¾"	12
	39,000	40,145	39,653	10' 4"	72' 3¾"	12
	40,000	41,004	40,443	10' 4"	73' 8¼"	14
12 ft	20,000	20,781	20,638	11' 11"	29' 4"	6
	25,000	25,541	25,381	11' 11"	35' 7"	8
	30,000	31,253	31,072	11' 11"	43' 1"	10
	25,000	36,013	35,815	11' 11"	49' 4"	12
	40,000	39,821	39,609	11' 11"	54' 4"	12
	45,000	45,131	44,352	11' 11"	60' 7"	16
	48,000	48,389	48,146	11' 11"	65' 7"	18
	50,000	50,293	50,044	11' 11"	68' 1"	18

APPENDIX A2

Actual Capacities and Dimensions of Single-Wall and Double-Wall Tanks Manufactured in Canada, and Installed in the United States (Green Tanks)

Refer to the Introduction of the Installation Manual for guidelines on the use of this chart.

	Nominal Capacity (gallons)	Actual Capacity (gallons)		Actual Tank Diameter (feet/inches)	Actual Tank Length (feet/inches)	Anchor Straps (# if required)
	SW & DW	SW	DW	SW & DW	SW & DW	
4 ft	600	610	671	4' 1 ³ / ₁₆ " SW 4' 1 ¹ / ₁₆ " DW	7' 4 ⁹ / ₁₆ " SW 7' 4 ¹³ / ₁₆ " DW	2 2
	750	773	773	4' 1 ³ / ₁₆ " SW 4' 1 ¹ / ₁₆ " DW	8' 3 ³ / ₁₆ " SW	2
	1000	1036	1086	4' 1 ³ / ₁₆ " SW 4' 1 ¹ / ₁₆ " DW	11' 1 ³ / ₈ " SW 11' 4 ¹ / ₄ " DW	2 2
	1,300	1,340	1,340	4' 1 ³ / ₁₆ " SW 4' 1 ¹ / ₁₆ " DW	14' 3 ¹⁵ / ₁₆ " SW	2
6 ft	1,500	1,794	–	6' 3 ¹ / ₄ "	10' 8" SW	2
	2,000	2,650	–	6' 3 ¹ / ₄ "	14' 9 ¹ / ₄ " SW	2
	2,500	–	2,635	6' 3 ¹ / ₄ "	14' 10 ¹ / ₄ " DW	2

Continued on Next Page →

	Nominal Capacity (gallons)	Actual Capacity (gallons)		Actual Tank Diameter (feet/inches)	Actual Tank Length (feet/inches)	Anchor Straps (# if required)
	SW & DW	SW	DW	SW & DW	SW & DW	
6 ft	3,000	3,045	3,008	6'3¼"	16'8"	2
	4,000	4,036	4,038	6'3¼"	21'5" SW 21'8" DW	2 2
	5,000	5,335	4,900	6'3¼"	27'7¾" SW 25'10¼" DW	4
	6,000	6,609	6,002	6'3¼"	33'9" SW 31'2½" DW	4
8 ft	4,000	3,982	4,336	8'6"	13'¾" SW 14'¾" DW	2
	5,000	5,387	4873	8'6"	16'8½" SW 15'5½" DW	2
	6,000	6,041	5993	8'6"	18'4½"	2
	7,000	6,631	7194	8'6"	19'10¾" SW 21'6" DW	2
	8,000	8,902	8,090	8'6"	23'8" SW 23'10" DW	4
	9,000	9,271	9,163	8'6"	26'8½" SW 26'7½" SW	4
	10,000	9,780	9,699	8'6"	28'¼"	4
	11,000	10,797	10,924	8'6"	30'7¾" SW 31'2½" DW	4
	12,000	12,907	11,996	8'6"	34'	4
	13,000	13,236	13,069	8'6"	36'11¼" SW 36'9½" DW	4
	14,000	14,528	14,021	8'6"	40'3¼"	6
	15,000	15,222	15,094	8'6"	42'¾"	6
	16,000	16,086	16,166	8'6"	44'3½" SW 44'10¼" DW	6
17,000	17,386	17,239	8'6"	47'7¾"	6	
10 ft	8,000	8,500	8,430	10'5½"	16'1¾"	4
	9,000	9,325	9,247	10'5½"	17'6½"	4
	10,000	10,144	10,065	10'5½"	18'11¼"	4
	11,000	11,166	11,073	10'5½"	20'7⅞"	4
	12,000	11,991	11,897	10'5½"	22'¾"	4
	13,000	13,401	13,288	10'5½"	24'5¼"	4

Continued on Next Page

	Nominal Capacity (gallons)	Actual Capacity (gallons)		Actual Tank Diameter (feet/inches)	Actual Tank Length (feet/inches)	Anchor Straps (# if required)
	SW & DW	SW	DW	SW & DW	SW & DW	
10 ft	14,000	15,014	14,253	10'5½"	27'2" SW 26'1" DW	4
	15,000	15,199	15,071	10'5½"	27'5¾"	5
	16,000	16,073	15,938	10'5½"	28'11½"	5
	17,000	17,546	17,525	10'5½"	31'5" SW 31'8" DW	5
	18,000	18,499	18,343	10'5½"	33'¾"	6
	19,000	19,115	18,953	10'5½"	34'1¼"	6
	20,000	20,100	19,930	10'5½"	35'9¼"	6
	21,000	21,418	21,236	10'5½"	38'	6
	22,000	22,575	22,384	10'5½"	39'11½"	7
	23,000	22,748	22,555	10'5½"	40'3"	7
	24,000	24,299	24,093	10'5½"	42'10½"	7
	25,000	25,297	25,106	10'5½"	44'7¼"	8
	26,000	26,147	25,925	10'5½"	46'	8
	27,000	26,775	26,547	10'5½"	47'¾"	8
	28,000	28,622	28,378	10'5½"	50'2¼"	10
	29,000	29,447	29,196	10'5½"	51'7"	10
	30,000	30,173	29,916	10'5½"	52'9¾"	10
	35,000	35,308	-	10'5½"	61'6" SW	12
40,000	40,468	-	10'5½"	70'2¾" SW	14	

APPENDIX A3

Actual Capacities and Dimensions of Single-Wall and Double-Wall Tanks Manufactured and Installed in Canada (Green Tanks)

Refer to the Introduction of the Installation Manual for guidelines on the use of this chart.

	Nominal Capacity (liters)		Actual Capacity (liters)		Actual Tank Diameter (millimeters)	Actual Tank Length (millimeters)		Anchor Straps (# if required)
	SW & DW	SW	DW	SW & DW	SW	DW	SW & DW	
4 ft	2,500	2,538	2,538	1,249	2,295	2,303	2	
	3,900	3,924	3,924	1,249	3,387	3,395	2	
	5,000	5,073	5,073	1,249	4,368	4,380	2	
6 ft	10,000	10,030	10,006	1,910	4,502	4,520	2	
	15,000	15,277	15,283	1,910	6,528	6,604	4	
	20,000	20,196	20,040	1,910	8,426	8,465	4	
	25,000	25,015	25,038	1,910	10,287	10,420	4	
8 ft	15,000	15,073	15,019	2,590	3,981	3,994	2	
	20,000	20,391	20,472	2,590	5,086	5,137	2	
	25,000	25,097	25,018	2,590	6,064	6,090	2	
	30,000	30,629	30,620	2,590	7,214	7,264	4	
	35,000	35,091	35,014	2,590	8,141	8,185	4	
	40,000	40,867	40,772	2,590	9,341	9,392	4	
	45,000	45,788	45,405	2,590	10,363	10,363	4	
	50,000	50,097	50,009	2,590	11,259	11,328	4	
	60,000	60,885	60,371	2,590	13,500	13,500	6	
65,000	65,806	65,247	2,590	14,522	14,522	6		
10 ft	50,000	50,723	50,301	3,188	7,449	7,449	4	
	55,000	56,829	56,348	3,188	8,280	8,280	4	
	60,000	60,838	60,329	3,188	8,827	8,827	5	
	65,000	66,338	65,780	3,188	9,576	9,576	5	
	70,000	72,351	71,740	3,188	10,395	10,395	6	
	75,000	76,079	75,436	3,188	10,903	10,903	6	
	80,000	81,067	80,378	3,188	11,582	11,582	6	
	85,000	86,101	85,370	3,188	12,268	12,268	7	
90,000	91,973	91,191	3,188	13,068	13,068	7		

Continued on Next Page →

	Nominal Capacity (liters)	Actual Capacity (liters)		Actual Tank Diameter (millimeters)	Actual Tank Length (millimeters)	Actual Tank Length (millimeters)	Anchor Straps (# if required)
	SW & DW	SW	DW	SW & DW	SW	DW	SW & DW
10 ft	100,000	101,342	100,484	3,188	14,345	14,345	8
	110,000	111,457	110,512	3,188	15,723	15,723	9
	115,000	114,207	–	3,188	16,097	–	10
	135,000	133,643	–	3,188	18,745	–	12
	150,000	153,173	–	3,188	21,406	–	14

APPENDIX A4

Actual Capacities and Dimensions of 10'-Diameter Double-Wall Tanks Manufactured in the United States and Installed in Canada (Red Tanks)

Refer to the Introduction of the Installation Manual for guidelines on the use of this chart.

	Nominal Capacity (gallons)	Nominal Capacity (liters)	Actual Capacity (liters)	Actual Tank Diameter (millimeters)	Actual Tank Length (millimeters)	Anchor Straps (# if required)
	10 ft	30,000	115,000	114,201	3,150	17,012
31,000		120,000	120,181	3,150	17,850	10
33,000		125,000	126,162	3,150	18,688	10
35,000		130,000	132,142	3,150	19,526	12
36,000		135,000	138,122	3,150	20,364	12
37,000		140,000	141,116	3,150	20,784	12
38,000		145,000	144,106	3,150	21,203	12
39,000		150,000	150,087	3,150	22,041	12
40,000		155,000	153,077	3,150	22,460	14

APPENDIX BI

Weights of Single-Wall, Double-Wall and Multicompartment Tanks Manufactured and Installed in the United States (Red Tanks)

Refer to the Introduction of the Installation Manual for guidelines on the use of this chart.

	Nominal Capacity (gallons)	SW Weight (pounds)	1 Compartment		2 Compartments		3 Compartments	
			DW Dry Weight (pounds)	DW Wet Weight (pounds)	DW Dry (pounds)	DW Wet (pounds)	DW Dry (pounds)	DW Wet (pounds)
4 ft	600	600	900	1,100				
	700	700	1,100	1,300				
	1,000	900	1,400	1,700				
	1,500	1,400	2,100	2,600				
	2,000	1,800	2,800	3,400				
6 ft	1,500	1,000						
	2,000	1,300						
	2,500	-	2,200	2,800				
	3,000	1,600	2,600	3,300				
	4,000	2,200	3,600	4,400	4,000	4,900		
	5,000	2,600	4,300	5,200	4,700	5,700		
	6,000	3,000	5,000	6,100	5,400	6,600		
	7,000	3,500			6,200	7,500		
	8,000	4,100			7,100	8,600	7,500	9,100
	9,000	4,600			7,900	9,500	8,300	10,000
	10,000	5,000			8,600	10,300	9,000	10,800
	11,000	5,600			9,700	11,500	10,100	12,000
	12,000	6,100			10,400	12,300	10,800	12,800
8 ft	2,000	1,000						
	3,000	1,400						
	4,000	1,800	2,700	3,600				
	5,000	2,200	3,200	4,200				
	5,500	2,400	3,500	4,600				
	6,000	2,600	3,700	4,900	4,300	5,800		
	7,000	3,000	4,300	5,500	4,900	6,400		
	8,000	3,400	4,800	6,200	5,400	7,100	6,000	8,000
	9,000	3,800	5,400	6,800	6,000	7,700	6,600	8,600
	10,000	4,200	5,900	7,500	6,500	8,400	7,100	9,300

Continued on Next Page

	Nominal Capacity (gallons)	SW Weight (pounds)	1 Compartment		2 Compartments		3 Compartments			
			DW Dry Weight (pounds)	DW Wet Weight (pounds)	DW Dry (pounds)	DW Wet (pounds)	DW Dry (pounds)	DW Wet (pounds)		
8 ft	11,000	4,700	6,400	8,100	7,000	9,000	7,600	9,900		
	12,000	5,100	7,000	8,800	7,600	9,700	8,200	10,600		
	13,000	5,600	7,600	9,500	8,200	10,400	8,800	11,300		
	14,000	6,000	8,200	10,200	8,800	11,100	9,400	12,000		
	15,000	6,600	9,100	11,200	9,700	12,100	10,300	13,000		
	16,000	7,000			10,200	12,800	10,800	13,700		
	17,000	7,200			10,500	13,100	11,100	14,000		
	18,000	7,600			11,000	13,700	11,600	14,600		
	19,000	8,000			11,600	14,400	12,200	15,300		
	20,000	8,600			12,400	15,400	13,000	16,300		
	21,000	9,000			12,900	16,000	13,500	16,900		
	22,000	9,200			13,200	16,300	13,800	17,200		
	23,000	9,700			13,800	17,100	14,400	18,000		
	24,000	10,100			14,400	17,700	15,000	18,600		
25,000	10,800	15,200			18,700	15,800	19,600			
10 ft	6,000	2,800								
	7,000	3,100								
	8,000	3,500	3,900	5,200						
	9,000	3,800	4,200	5,600						
	10,000	4,500	4,900	6,400					5,900	7,800
	11,000	4,800	5,200	6,800	6,200	8,200				
	12,000	5,100	5,600	7,200	6,600	8,600				
	13,000	5,500	5,900	7,600	6,900	9,000				
	14,000	5,800	6,300	8,000	7,300	9,400				
	15,000	6,600	7,000	8,900	8,000	10,300			9,000	11,700
	16,000	7,200	7,700	9,700	8,700	11,100			9,700	12,500
	17,000	7,600	8,000	10,100	9,000	11,500			10,000	12,900
	18,000	7,900	8,400	10,500	9,400	11,900	10,400	13,300		
	19,000	8,200	8,700	10,900	9,700	12,300	10,700	13,700		
	20,000	8,600	9,000	11,300	10,000	12,700	11,000	14,100		
21,000	9,400	10,200	12,600	11,200	14,000	12,200	15,400			

Continued on Next Page →

	Nominal Capacity (gallons)	SW Weight (pounds)	1 Compartment		2 Compartments		3 Compartments	
			DW Dry Weight (pounds)	DW Wet Weight (pounds)	DW Dry (pounds)	DW Wet (pounds)	DW Dry (pounds)	DW Wet (pounds)
10 ft	22,000	9,700	10,500	13,000	11,500	14,400	12,500	15,800
	23,000	10,100	10,800	13,400	11,800	14,800	12,800	16,200
	24,000	10,400	11,200	13,800	12,200	15,200	13,200	16,600
	25,000	11,100	11,800	14,600	12,800	16,000	13,800	17,400
	26,000	11,400	12,200	15,000	13,200	16,400	14,200	17,800
	27,000	11,700	12,500	15,500	13,500	16,900	14,500	18,300
	28,000	12,100	12,900	15,900	13,900	17,300	14,900	18,700
	29,000	12,800	13,500	16,700	14,500	18,100	15,500	19,500
	30,000	13,200	14,000	17,200	15,000	18,600	16,000	20,000
	31,000	13,900	14,700	18,100	15,700	19,500	16,700	20,900
	32,000	14,200	15,000	18,500	16,000	19,900	17,000	21,300
	33,000	14,600	15,400	18,900	16,400	20,300	17,400	21,700
	34,000	14,900	15,700	19,300	16,700	20,700	17,700	22,100
	35,000	15,400	16,500	20,100	17,500	21,500	18,500	22,900
	36,000	16,000	17,200	20,900	18,200	22,300	19,200	23,700
	37,000	16,400	17,500	21,300	18,500	22,700	19,500	24,100
	38,000	16,700	17,800	21,700	18,800	23,100	19,800	24,500
	39,000	17,400	18,500	22,600	19,550	24,000	20,500	25,400
	40,000	17,900	19,000	23,100	20,000	24,500	21,000	25,900
	12 ft	20,000	9,200	14,000	16,700			
25,000		10,800	16,600	19,700				
30,000		13,100	19,900	23,500				
35,000		14,700	22,500	26,500				
40,000		16,100	24,600	28,900				
45,000		18,000	27,400	32,100				
48,000		19,300	29,500	34,500				
50,000		20,000	30,500	35,700				
60,000		23,500						

APPENDIX B2

Weights of Single-Wall, Double-Wall and Multicompartment Tanks Manufactured in Canada and Installed in the United States (Green Tanks)

Refer to the Introduction of the Installation Manual for guidelines on the use of this chart.

	Nominal Capacity (gallons)	SW Weight (pounds)	1 Compartment		2 Compartments		3 Compartments	
			DW Dry Weight (pounds)	DW Wet Weight (pounds)	DW Dry (pounds)	DW Wet (pounds)	DW Dry (pounds)	DW Wet (pounds)
4 ft	600	700	800	1,000				
	750	700	900	1,100				
	1,000	800	1,000	1,300				
	1,300	1,100	1,300	1,700				
6 ft	1,500	800	1,400	1,700				
	2,000	900	1,500	1,900				
	2,500	1,100	1,900	2,300				
	3,000	1,200	2,100	2,600	2,400	3,100		
	4,000	1,700	2,900	3,400	3,200	3,900		
	5,000	2,000	3,500	4,100	3,800	4,600		
	6,000	2,400	4,200	4,800	4,500	5,300		
8 ft	4,000	1,600	2,200	2,700				
	5,000	1,800	2,400	2,900				
	6,000	2,200	2,900	3,500				
	7,000	2,500	3,400	4,000				
	8,000	2,900	3,900	4,600	4,400	5,300		
	9,000	3,300	4,300	5,100	4,800	5,800		
	10,000	3,500	4,600	5,400	5,100	6,100	5,600	6,800
	11,000	3,900	5,100	6,000	5,600	6,700	6,100	7,400
	12,000	4,300	5,600	6,500	6,100	7,200	6,600	7,900
	13,000	4,700	6,000	7,100	6,500	7,800	7,000	8,500
	14,000	5,100	6,700	7,700	7,200	8,400	7,700	9,100
	15,000	5,500	7,200	8,300	7,700	9,000	8,200	9,700
	16,000	5,900	7,600	8,800	8,100	9,500	8,600	10,200
	17,000	6,300	8,100	9,400	8,600	10,100	9,100	10,800
10 ft	8,000	3,900	4,300	5,000				
	9,000	4,200	4,600	5,400				
	10,000	4,500	5,000	5,800				

Continued on Next Page →

	Nominal Capacity (gallons)	SW Weight (pounds)	1 Compartment		2 Compartments		3 Compartments	
			DW Dry Weight (pounds)	DW Wet Weight (pounds)	DW Dry (pounds)	DW Wet (pounds)	DW Dry (pounds)	DW Wet (pounds)
10 ft	11,000	4,900	5,300	6,100				
	12,000	5,200	5,700	6,500				
	13,000	5,800	6,300	7,300				
	14,000	6,100	6,700	7,600	8,200	9,500	9,700	11,400
	15,000	6,400	7,000	8,000	8,500	9,900	10,000	11,800
	16,000	6,800	7,300	8,400	8,800	10,300	10,300	12,200
	17,000	7,400	8,000	9,200	9,500	11,100	11,000	13,000
	18,000	7,700	8,400	9,500	9,900	11,400	11,400	13,300
	19,000	8,000	8,700	9,900	10,200	11,800	11,700	13,700
	20,000	8,300	9,000	10,300	10,500	12,200	12,000	14,100
	21,000	8,700	9,600	10,900	11,100	12,800	12,600	14,700
	22,000	9,300	10,300	11,600	11,800	13,500	13,300	15,400
	23,000	9,300	10,300	11,600	11,800	13,500	13,300	15,400
	24,000	10,000	11,000	12,400	12,500	14,300	14,000	16,200
	25,000	10,300	11,300	12,800	12,800	14,700	14,300	16,600
	26,000	10,600	11,600	13,200	13,100	15,100	14,600	17,000
	27,000	10,900	12,000	13,500	13,500	15,400	15,000	17,300
	28,000	11,600	12,700	14,300	14,200	16,200	15,700	18,100
	29,000	11,900	13,000	14,700	14,500	16,600	16,000	18,500
	30,000	12,200	13,300	15,100	14,800	17,000	16,300	18,900
35,000	14,100							
40,000	16,100							

APPENDIX B3

Weights of Single-Wall, Double-Wall and Multicompartment Tanks Manufactured and Installed in Canada (Green Tanks)

Refer to the Introduction of the Installation Manual for guidelines on the use of this chart.

	Nominal Capacity (liters)	SW Weight (kilograms)	1 Compartment		2 Compartments		3 Compartments	
			DW Dry Weight (kilograms)	DW Wet Weight (kilograms)	DW Dry (kilograms)	DW Wet (kilograms)	DW Dry (kilograms)	DW Wet (kilograms)
4 ft	2,500	300	400	500				
	3,900	400	500	600				
	5,000	500	600	700				
6 ft	10,000	500	900	1,100				
	15,000	800	1,300	1,600	1,400	1,800		
	20,000	1,000	1,700	2,000	1,800	2,200		
	25,000	1,300	2,200	2,500	2,300	2,700		
8 ft	15,000	600	900	1,100				
	20,000	900	1,200	1,500				
	25,000	1,100	1,400	1,700				
	30,000	1,300	1,700	2,100				
	35,000	1,500	2,000	2,300	2,200	2,600		
	40,000	1,800	2,300	2,700	2,500	3,000		
	45,000	1,900	2,500	3,000	2,700	3,300		
	50,000	2,100	2,700	3,200	2,900	3,500	3,100	3,800
	55,000	2,400	3,100	3,600	3,300	3,900	3,500	4,200
	60,000	2,600	3,400	3,900	3,600	4,200	3,800	4,500
65,000	2,900	3,700	4,300	3,900	4,600	4,100	4,900	
10 ft	50,000	2,600	2,900	3,300				
	55,000	2,900	3,200	3,600				
	60,000	3,100	3,300	3,800				
	65,000	3,400	3,600	4,200				
	70,000	3,600	3,900	4,500	4,600	5,300		
	75,000	3,800	4,100	4,700	4,800	5,500		
	80,000	4,000	4,400	4,900	5,100	5,700		
	85,000	4,200	4,700	5,300	5,400	6,100		
	90,000	4,500	5,000	5,600	5,700	6,400	6,400	7,200

Continued on Next Page →

	Nominal Capacity (liters)	SW Weight (kilograms)	1 Compartment		2 Compartments		3 Compartments	
			DW Dry Weight (kilograms)	DW Wet Weight (kilograms)	DW Dry (kilograms)	DW Wet (kilograms)	DW Dry (kilograms)	DW Wet (kilograms)
10 ft	95,000	4,700	5,100	5,800	5,800	6,600	6,500	7,400
	100,000	5,000	5,400	6,100	6,100	6,900	6,800	7,700
	110,000	5,400	5,900	6,700	6,600	7,500	7,300	8,300
	115,000	5,500						
	135,000	6,400						
	150,000	7,300						

APPENDIX B4

Weights of 10'-Diameter Double-Wall and Multicompartment Tanks Manufactured in the United States and Installed in Canada (Red Tanks)

Refer to the Introduction of the Installation Manual for guidelines on the use of this chart.

	Nominal Capacity (gallons)	Nominal Capacity (liters)	1 Compartment		2 Compartments		3 Compartments	
			DW Dry Weight (kilograms)	DW Wet Weight (kilograms)	DW Dry Weight (kilograms)	DW Wet Weight (kilograms)	DW Dry Weight (kilograms)	DW Wet Weight (kilograms)
10 ft	30,000	115,000	6,400	7,800	6,800	8,400	7,300	9,100
	31,000	120,000	6,700	8,200	7,100	8,900	7,600	9,500
	33,000	125,000	7,000	8,600	7,400	9,200	7,900	9,900
	35,000	130,000	7,500	9,100	7,900	9,800	8,400	10,400
	36,000	135,000	7,800	9,500	8,300	10,100	8,700	10,800
	37,000	140,000	7,900	9,700	8,400	10,300	8,900	10,900
	38,000	145,000	8,100	9,900	8,500	10,500	9,000	11,100
	39,000	150,000	8,400	10,300	8,900	10,900	9,300	11,500
	40,000	155,000	8,600	10,500	9,100	11,100	9,500	11,800

APPENDIX C

Primary Backfill Requirements

1. The backfill material surrounding an underground storage tank (UST) is a critical part of a proper tank installation. This document gives guidelines for choosing the primary backfill material to use when installing our fiberglass underground storage tanks.

2. The Installation Manual specifies that select rounded stones or crushed stones are to be used as primary backfill material.

3. Primary backfill material is to be clean, free-flowing, and free of dirt, sand, large rocks, roots, organic materials, debris, ice and snow.

4. No backfill material shall be frozen or contain lumps of frozen material at any time during placement.

5. Another important characteristic of good backfill material is hardness or stability when exposed to water or loads. Most materials have no problems meeting the hardness requirement.

- Materials like soft limestone, sandstone, sea shells or shale should not be used as backfill because they break down over time.

6. Coarse aggregate is a technical term for the material (rounded stones and crushed stones) that meets our backfill size requirements.

7. ASTM International and the American Association of State Highway and Transportation Officials have specifications for standard sizes of coarse aggregate.

- Table C-1** gives the standard sizes of coarse aggregate that meet the backfill material specifications for rounded stones and crushed stones. It identifies standard sieve sizes used to grade aggregate material. For each aggregate size, the amount of material finer than each laboratory sieve (square openings) is given as a percentage of the total weight of the sample.
- ASTM uses size numbers 6, 67, 7 and 8 to describe specific gradation profiles for materials that pass through a series of sieves. Do not confuse these gradation profiles with sieve sizes.
- C2.3.1. The percentages give an indication of the particle size distribution or gradation within a given aggregate size. With aggregate size number 6 of rounded stones, for example, 20–55 percent of the sample (measured by weight) should pass through a ½-inch sieve. And, with aggregate size number 7 of crushed stones, 0–15 percent of the sample (measured by weight) should pass through a No. 4 sieve.

8. Some material suppliers may produce materials that meet our requirements but are not identified by a standard coarse aggregate size number. The supplier should be able to provide a specification that identifies the size or gradation of the material.

- If the material supplier is unable to supply a gradation report, an independent testing laboratory can perform a sieve analysis on a sample of the material according to the ASTM C 136 testing specifications. The test results can then be compared against the size requirements for rounded or crushed stones shown in **Table C-1**.



9. When using select rounded stones, the material is to be a mix of rounded particles, sizes between 0.094 inch [2.36 mm] and ¾ inch [19 mm].

- The rounded stones must conform to the specifications of ASTM C 33, sizes 6, 67 or 7.
- No more than 5 percent (by weight) of the backfill may pass through a #8 sieve. See **Table C-1** for additional information about specifications.
- Generally, rounded stones that meet the gradation requirements are larger than allowable crushed stones.

10. When using crushed stones, the material is to be a mix of angular particles, sizes between 0.094 inch [2.36 mm] and ½ inch [12.55 mm].

- The crushed stones must conform to the specifications of ASTM C 33, sizes 7 or 8.
- No more than 5 percent (by weight) of the backfill may pass through a #8 sieve. See **Table C-1** for additional information.

Table C-1

PERCENTAGE OF STONES PASSING THROUGH SIEVE BY SIEVE SIZE			
Rounded Stones			
ASTM C 33 Size #	#6 Stone	#67 Stone	#7 Stone
1 inch [25 mm]	100%	100%	---
¾ inch [19 mm]	90–100%	90–100%	100%
½ inch [12.5 mm]	20–55%	---	90–100%
⅜ inch [9.5 mm]	0–15%	20–55%	40–70%
No. 4 [4.75 mm]	0–5%	0–10%	0–15%
No. 8 [2.36 mm]	---	0–5%	0–5%
Crushed Stone			
ASTM C 33 Size #	#7 Stone	#8 Stone	
1 inch [25 mm]	---	---	
¾ inch [19 mm]	100%	---	
½ inch [12.5 mm]	90–100%	100%	
⅜ inch [9.5 mm]	40–70%	85–100%	
No. 4 [4.75 mm]	0–15%	10–30%	
No. 8 [2.36 mm]	0–5%	0–10%	

APPENDIX D

Split Backfill Guidelines

I. GENERAL

1.1. Use select rounded or crushed stones for primary backfill material as specified in the Installation Manual in effect at time of installation, and **Appendix C**, Primary Backfill Requirements.

2. SPLIT BACKFILL INSTALLATION

2.1. Use the primary backfill material vertically up to at least 75 percent of the tank diameter. See **Figure D-1**.

2.2. Follow the instructions in **section 5** of the Installation Manual on the placement of this backfill material.

2.3. Install a layer of geotextile fabric over the entire surface of the primary backfill material. See **section 1** for more information about geotextile filter fabric.

2.3.1. All joints in the geotextile fabric should be overlapped a minimum of 12 inches [30 cm].

2.3.2. Geotextile fabric must overlap onto the tank and excavation surface a minimum of 12 inches [30 cm].

2.3.3. Installations with unstable soil may require that the fabric line the entire excavation. See **section 1** for specific information about using geotextile or fabric in unstable in-situ (native) soil conditions.

2.4. Clean native backfill may be used as secondary backfill material above the geotextile fabric to subgrade.

2.4.1. Secondary backfill material must be clean, free-flowing, and free of large rocks, roots, organic materials, debris, ice and snow. Backfill material shall not be frozen or contain lumps of frozen material at any time during installation.

2.5. Secondary backfill must be compacted to achieve a minimum of 85 percent standard proctor density.

2.5.1. Do not use rammer-type compactors over the top of the tank.

2.5.2. Some tank owners may require sample testing and written reports to verify the compaction of the backfill.

2.6. Material must be installed in 12-inch [30-cm] to 24-inch [60-cm] lifts compatible with the compaction equipment used.

2.7. In some conditions, frost heave may be encountered when using secondary backfill. Therefore, consider any frost-related problems that may occur.

2.8. Specifications for secondary backfill material and compaction above the geotextile fabric layer may be determined by the requirements of the piping, surface slab or roadway.

2.9. Refer to applicable codes or standards for base course and sub-base course material and compaction requirements.

2.10. The following are examples of acceptable secondary backfill material:

- clean native backfill
- coarse sand or gravel

2.11. 100% of all backfill material must pass through a 1-inch sieve.

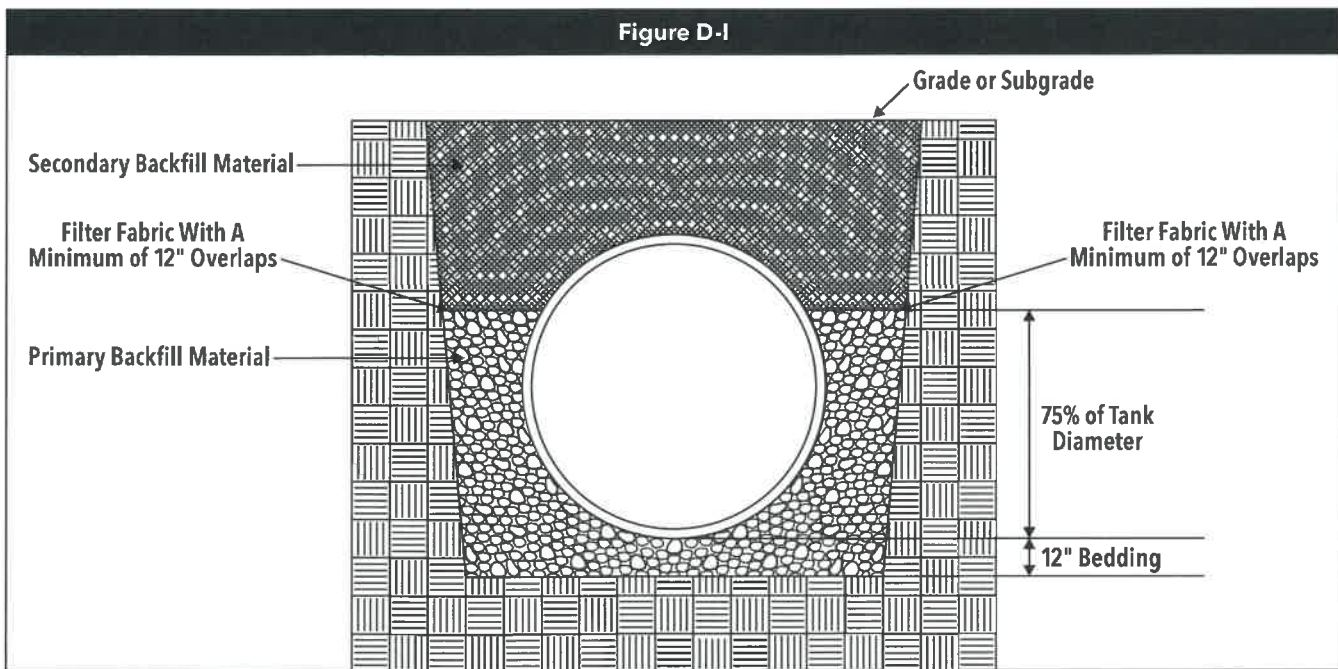

APPENDIX E

Tank Installation Checklist

TO INSTALLER: After tank installation, deliver the Installation Manual with the completed Tank Installation Checklist to the tank owner. Retain a copy of each for your records.

TO OWNER: After installation, retain the limited warranty, the Installation Manual and completed Tank Installation Checklist for future reference and to facilitate any warranty claim.

INSTALLATION DATE(S): _____ **PERSON COMPLETING FORM:** _____

INSTALLATION ADDRESS: _____

TANK INFORMATION	TANK #1	TANK #2	TANK #3	TANK #4
Tank type—Single-Wall (SW), Double-Wall (DW)				
Tank Usage (Fuel)—Fuel, DEF, Pipeline Sump				
Tank Usage (Water)—Potable Water, Water Collection				
Tank Usage (Wastewater)—Grease Interceptor, Septic, Industrial Wastewater/Chemical				
Tank Usage (Oil/Water Separator)				
Nominal Tank Diameter—give in feet				
Nominal Tank Capacity—give in gallons or liters (and note which)				
If applicable, UL/ULC # (read from tank label)—yes or no				

SITE INFORMATION (See section 1)	TANK #1	TANK #2	TANK #3	TANK #4
Primary backfill meets Appendix C requirements—yes or no				
Secondary backfill material will be used—yes or no				
Secondary backfill meets our requirements—yes or no				
Geotextile will be used—yes or no				
Excavation—shored or not shored				
Tank will see traffic loads (H20 or HS20)—yes or no				
Hole condition—dry or wet				
Anchoring system will be used—yes or no				
If applicable, anchoring system used—deadmen or anchor slab				

PREINSTALLATION INSPECTION AND TESTING (See sections 3 and 4)		TANK #1	TANK #2	TANK #3	TANK #4
Visual Inspection	Shipping damage—yes or no				
	Loss of vacuum—yes or no				
	Monitoring fluid visible on interior of tank—yes or no				
	Monitoring fluid visible on exterior of tank—yes or no				
Requirements met for double-wall tanks shipped under interstitial vacuum—yes or no					
Record fluid level in reservoir for double-wall wet tanks					
If required, tank passed pressure/soap test—yes or no					

Continued on Next Page →

INSTALLING TANKS (See sections 5 and 7)	TANK #1	TANK #2	TANK #3	TANK #4
Record tank diameter measurement #1 (before installation)				
Record final backfill bedding depth under tank—inches or centimeters				
Record final tank spacing between tanks—inches or centimeters				
Record final tank spacing from tank endcap to excavation walls—inches or centimeters				
If applicable, deadmen used—factory-supplied or other				
If applicable, anchoring hardware—factory-supplied or other				
Record diameter measurement #2 (after straps are installed)				
Subtract diameter measurement #2 from #1 and record				
Deflection measurement meets Table 1-6 requirements—yes or no				
Voids under tank between ribs and under domes filled with backfill and tamped—yes or no				
Backfill placement and compaction meet requirements—yes or no				
Piping connections meet requirements—yes or no				
Fittings and other metal components are coated for corrosion protection – yes or no				
Record diameter measurement #3 (after backfilling to top of tank is complete)				
Subtract diameter measurement #3 from #1 and record				
Deflection measurement meets Table 1-6 requirements—yes or no				
Tank was ballasted prior to bringing backfill to top of tank—yes or no				

After backfilling is brought to top of tank (See sections 5, 6 and 8)

Tank was ballasted after bringing backfill to top of tank—yes or no				
Postinstallation tests were conducted for pressure-testable tanks—yes or no				
If applicable, optional hydrostatic test was performed—yes or no				
If applicable, containment sump test was successful—yes or no				
Record final depth of backfill over tank—give in inches or centimeters				
Record diameter measurement #4 (after backfilling is brought to subgrade)				
Subtract diameter measurement #4 from #1 and record				
Final deflection measurement meets requirements of Table 1-6 —yes or no				
If applicable, type of surface pad used—concrete or asphalt				
If applicable, thickness of surface pad used—give in inches or centimeters and note which type				
If applicable, record monitoring fluid level when backfilling & top slab installation are complete				

SITE SKETCH (Indicate specifics of tank installation.)																			

ADDITIONAL NOTES
Note any variations and/or deviations from instructions (and attach written authorizations):

VERIFYING SIGNATURES	
CONTRACTOR	TANK OWNER/REPRESENTATIVE
I verify that this information is a true record of the installation of the tanks listed here.	I verify that this information is a true record of the installation of the tanks listed here, and that I have received a copy of the Installation Manual and this Tank Installation Checklist.
Name:	Name:
Telephone:	Telephone:
Email:	Email:
Address:	Address:
Signature:	Signature:
Date:	Date:

TO INSTALLER: After tank installation, deliver the Installation Manual with the completed Tank Installation Checklist to the tank owner. Retain a copy of each for your records.

TO OWNER: After installation, retain the limited warranty, the Installation Manual and completed Tank Installation Checklist for future reference and to facilitate any warranty claim.

Multiple Facilities

Customers can rely on timely manufacture and delivery of tanks and accessories.

With six manufacturing facilities throughout North America, we're never far from customers when they need fiberglass tanks and accessories shipped. Our US and Canadian facilities can provide tanks with UL, ULC, NSF and IAPMO listings to our customers.



Contact Us

On the Web:
www.zcl.com

Technical Support:
1.800.661.8265
USA: 952.887.1890
Email: eng.support@zcl.com

Corporate Head Office

ZCL Composites Inc.
1420 Parsons Road SW
Edmonton, AB T6X 1M5

US Office

Xerxes Corporation
7901 Xerxes Avenue S
Minneapolis, MN 55431

Manufacturing Facilities:

Canada

Edmonton 780-465-0726
Drummondville 819-474-4114

USA

Anaheim 714-630-0012
Hagerstown 301-223-6933
Tipton 563-886-6172
Seguin 830-372-0090